

Influence of Leonardo da Vinci

Dan Riffell, Scholar in Residence



Mechanical Engineering

UNIVERSITY OF COLORADO **BOULDER**

Agenda

- Introduction
- Leonardo in historical context
- Current influence

Renaissance Timeline

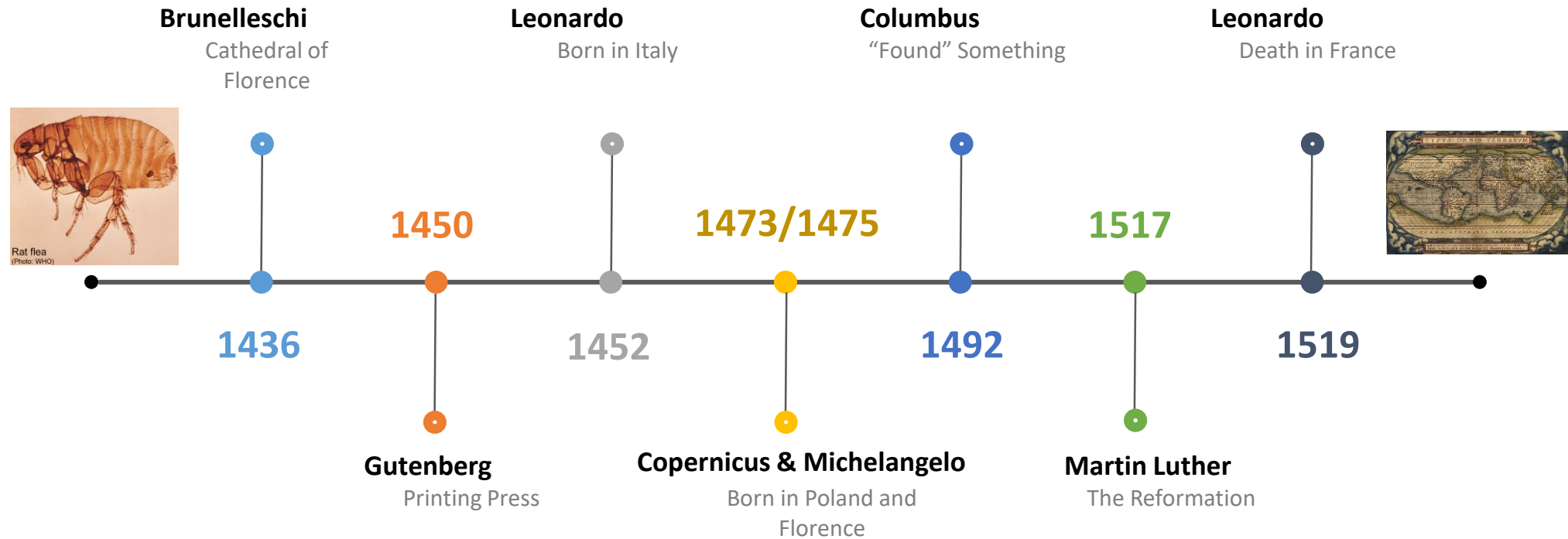



ATLANTIC OCEAN

PORTUGAL

Valladolid

CASTILE

Madrid

Toledo

SPAIN

Granada

ARAGON

FRANCE

Chambord

Fontainebleau

Paris

Isenheim

Strasbourg

GRAND DUCHY OF TUSCANY

Genoa

LOMBARDY

Milan

Zurich

Basel

Nuremberg

Mainz

Antwerp

Louvain

Brussels

Arras

North Sea

NETHERLANDS

Rotterdam

Amsterdam

Utrecht

Bruges

English Channel

ENGLAND

London

IRELAND

HOLY

ROMAN EMPIRE

Regensburg

Nuremberg

Halle

Wittenberg

Vienna

Danube R.

Augsburg

BAVARIA

REPUBLIC OF VENICE

Venice

Florence

PAPAL STATES

Adriatic Sea

Rome

Tyrrhenian Sea

KINGDOM OF NAPLES

Sicily

Ionian Sea

Mediterranean Sea

Baltic Sea

POLAND

OTTOMAN EMPIRE

Rebirth of Europe

- Break away from Dark Ages
- Started in Northern Italy where Muslim trade routes and ports encouraged exchange of ideas
- Changes in art, architecture, literature, science, technology, politics, and religion
- Materialistic rather than spiritual - separation from church
- Shift to studying mathematics, astronomy, and anatomy



a Vir

Cesar
Militar
F

5

1

er
in rectory

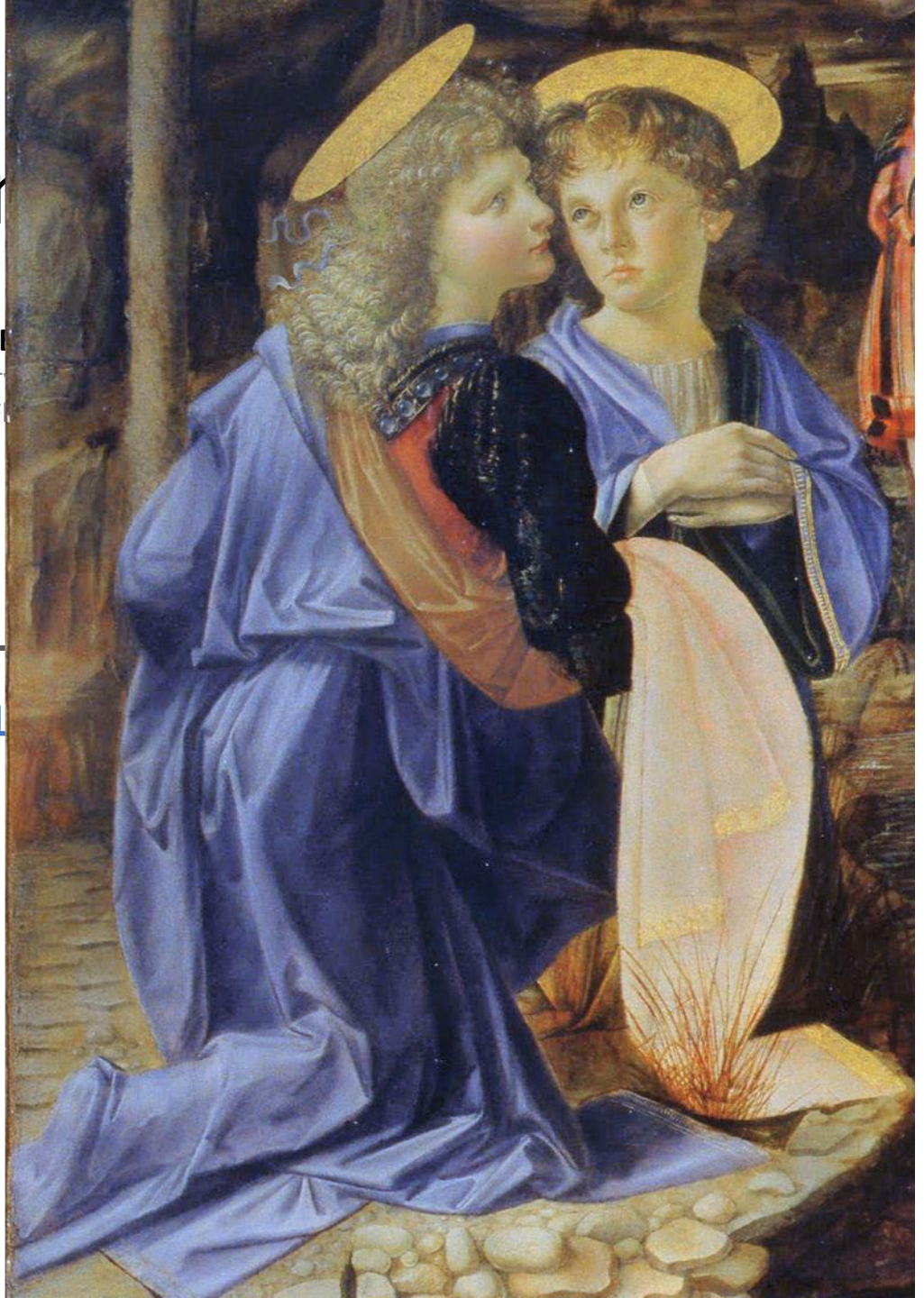

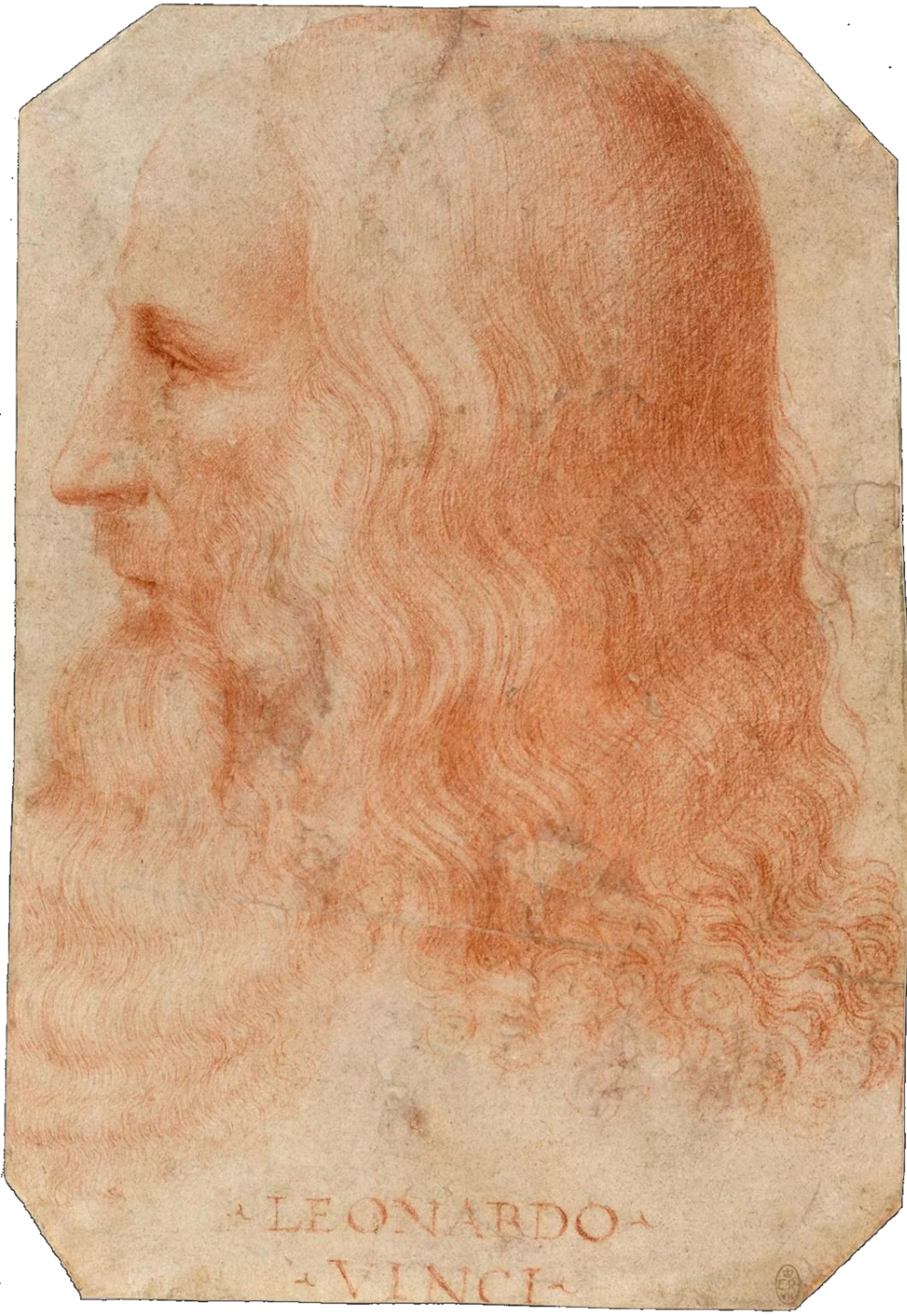

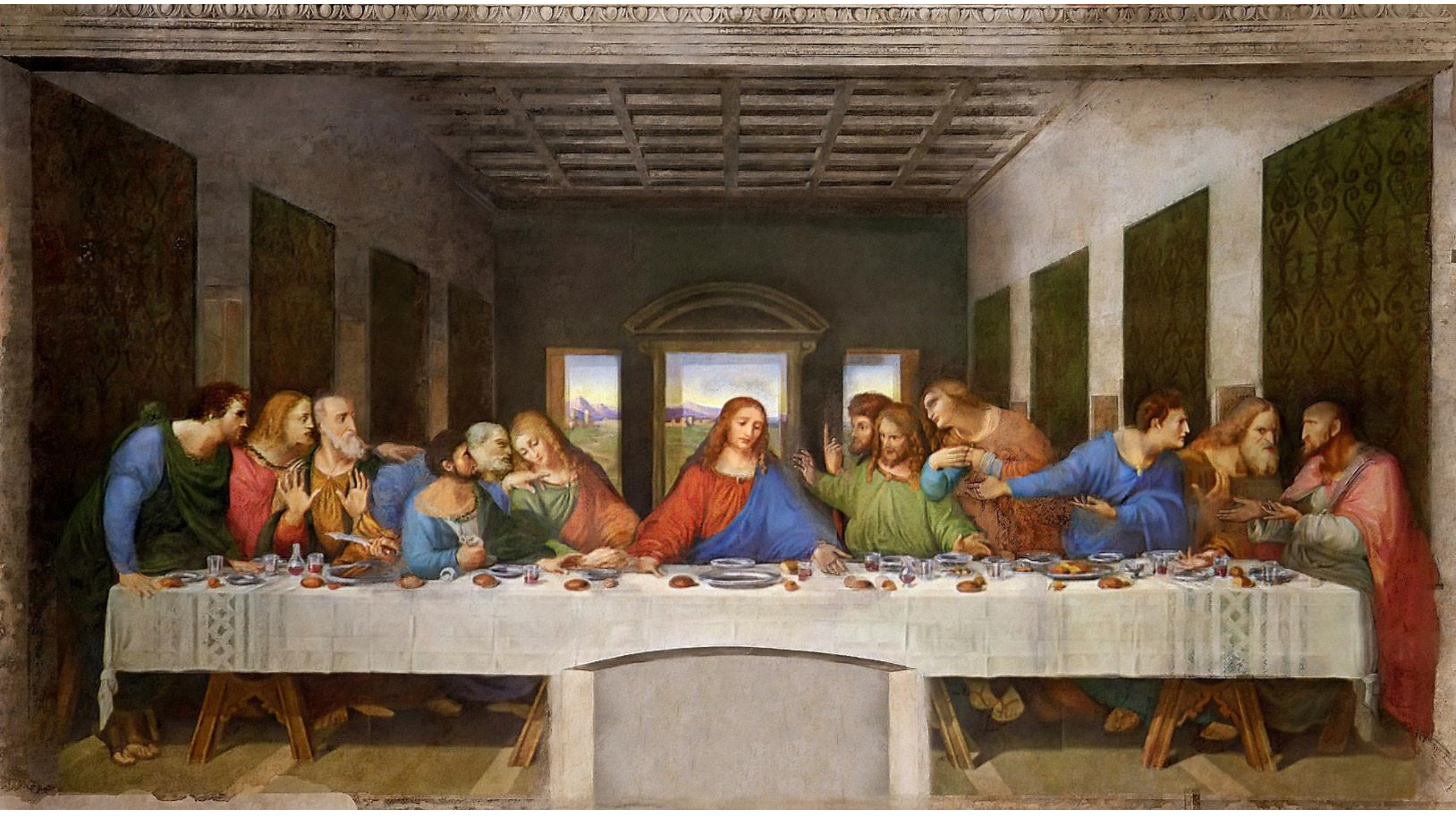

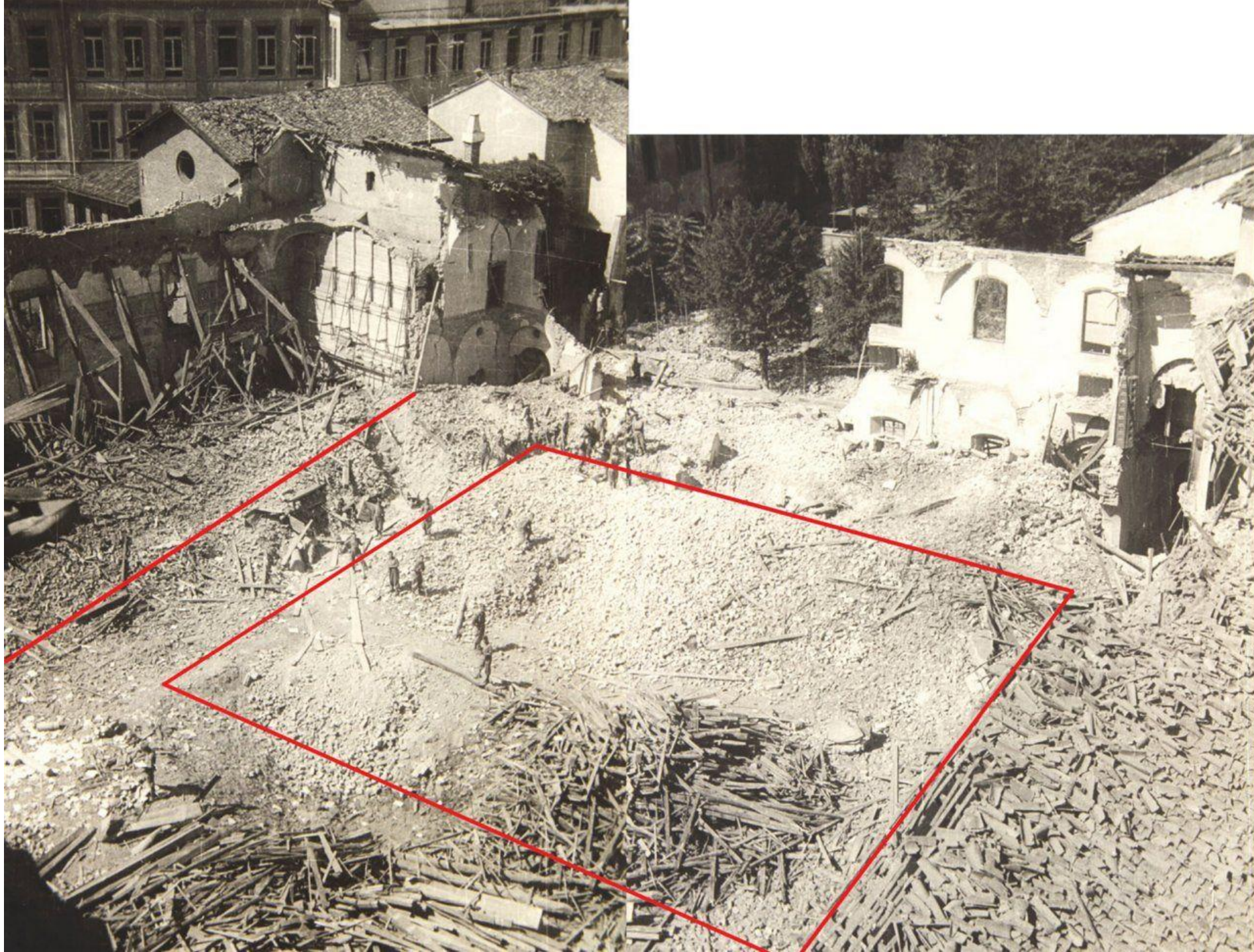





What was he really?

ARTIST?

INVENTOR?

SCIENTIST?

ENGINEER?

ARCHITECT?

MUSICIAN?

GENIUS?

Codices

- Estimates of over 15k pages
- Only 5k remain

Abnmas

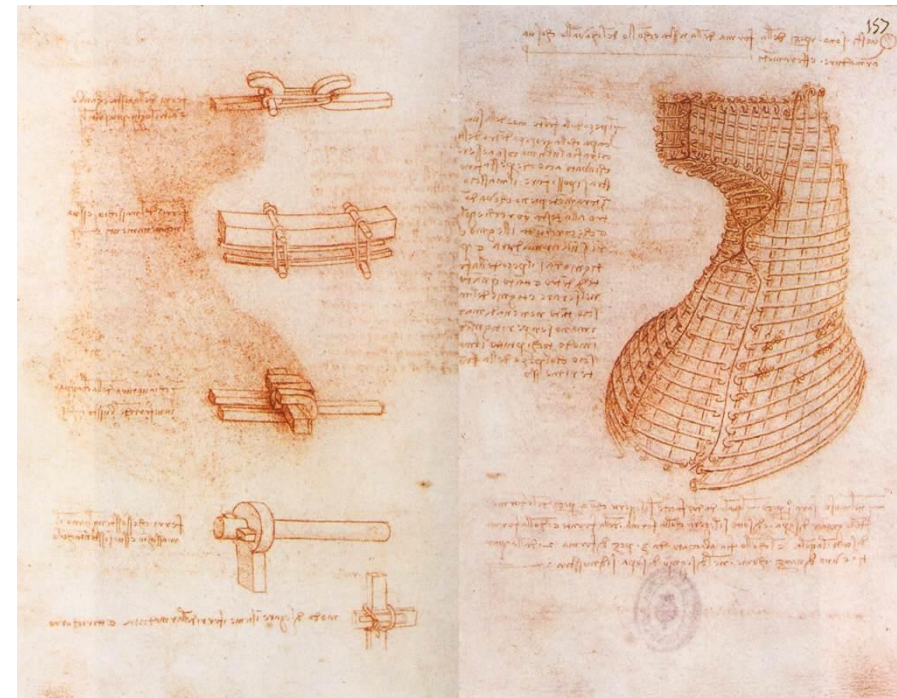
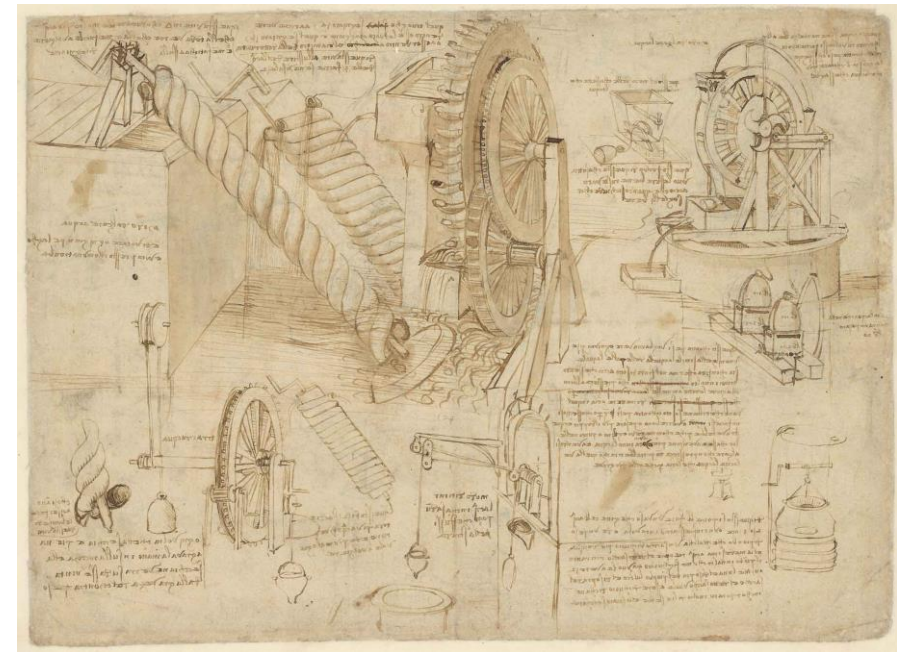
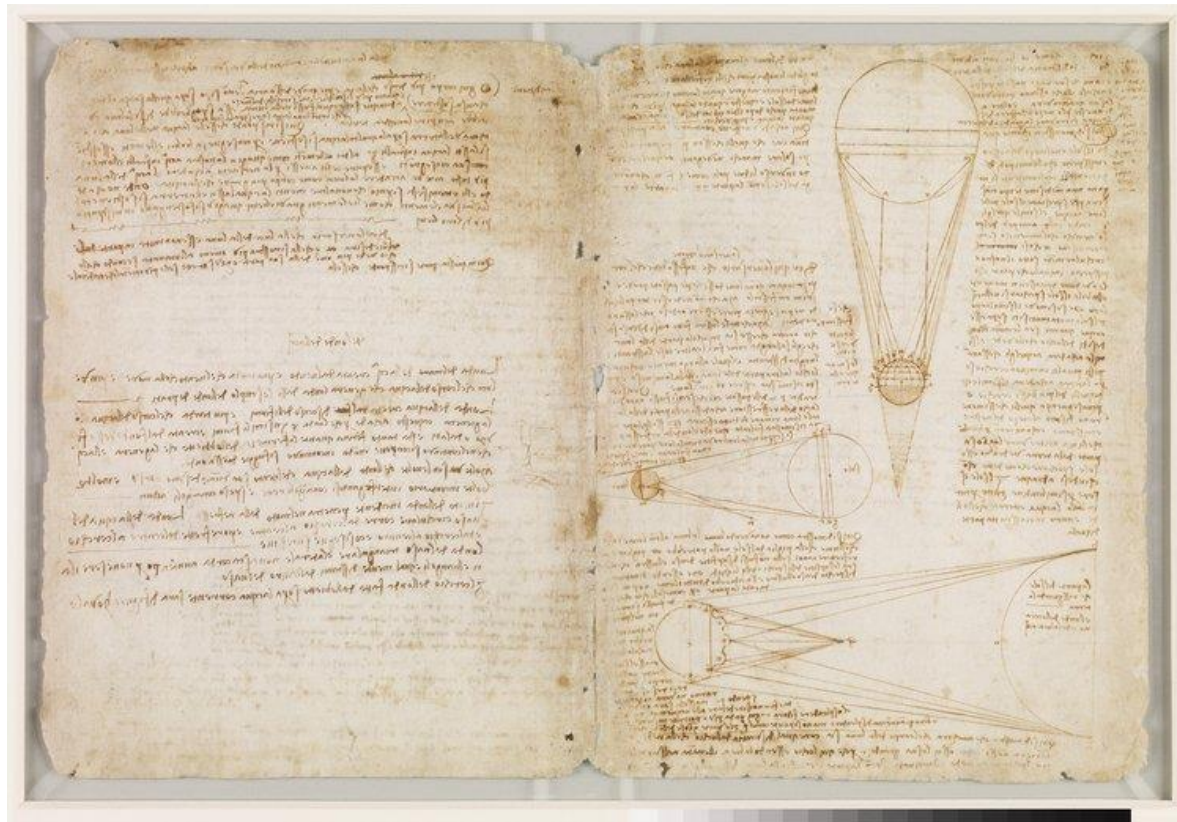

Flight

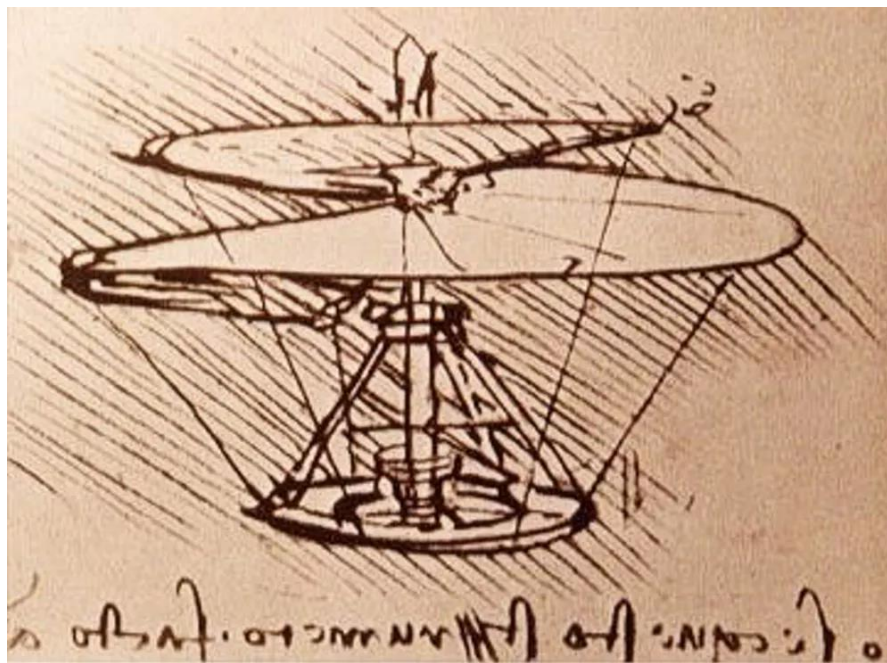

Civil Engineering

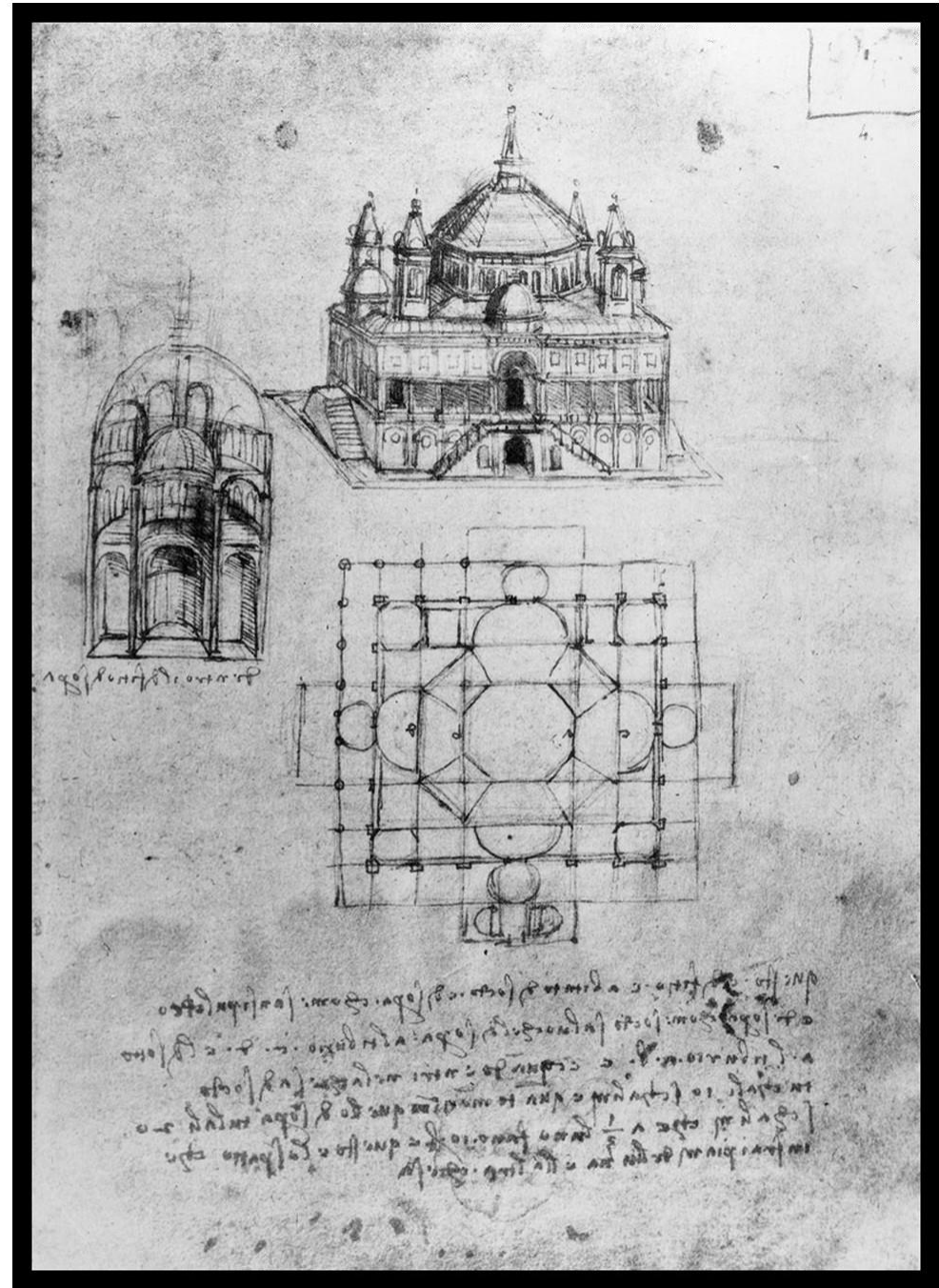
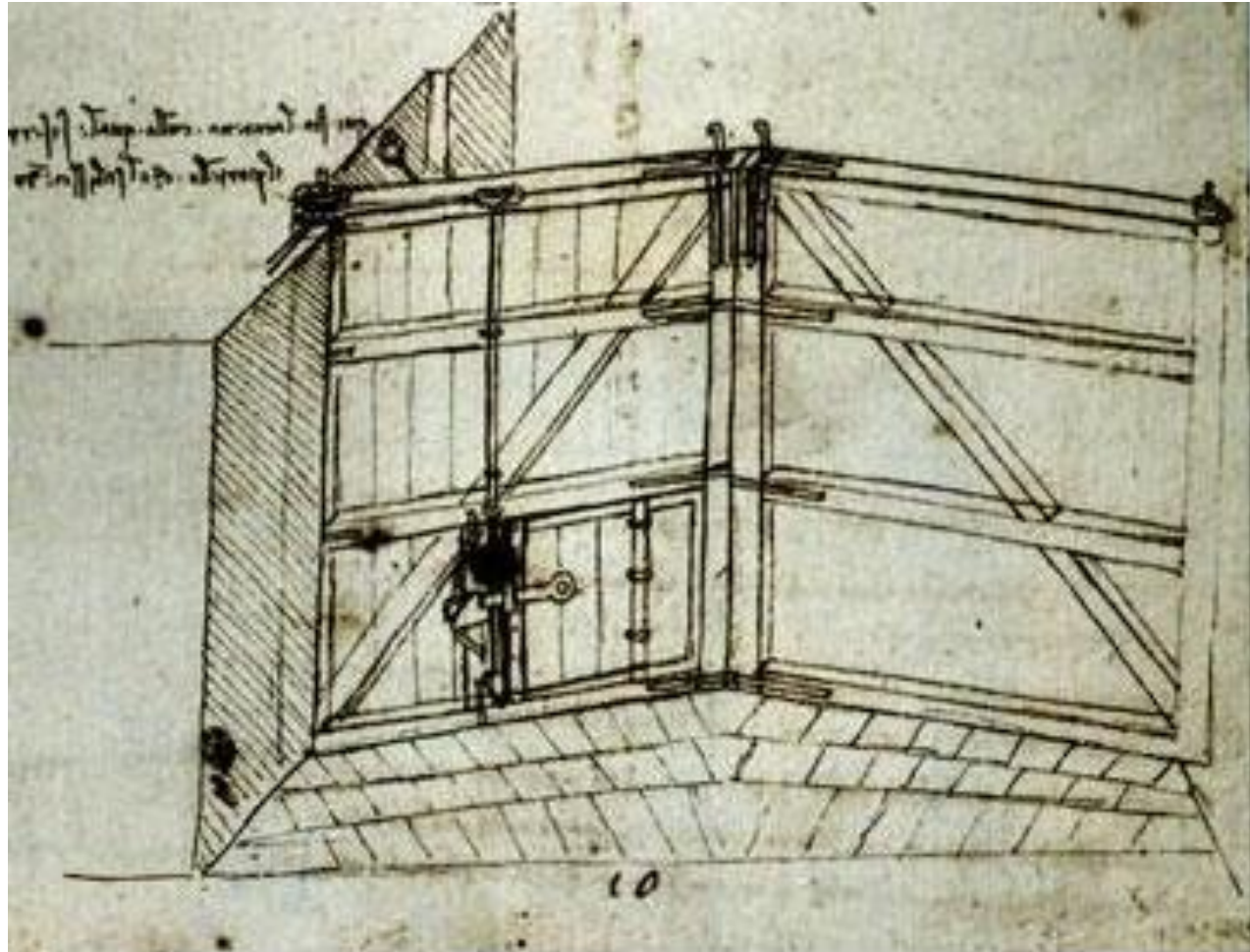
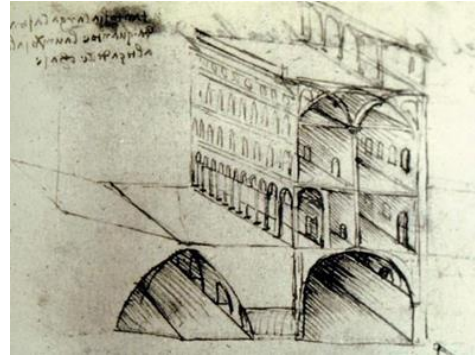

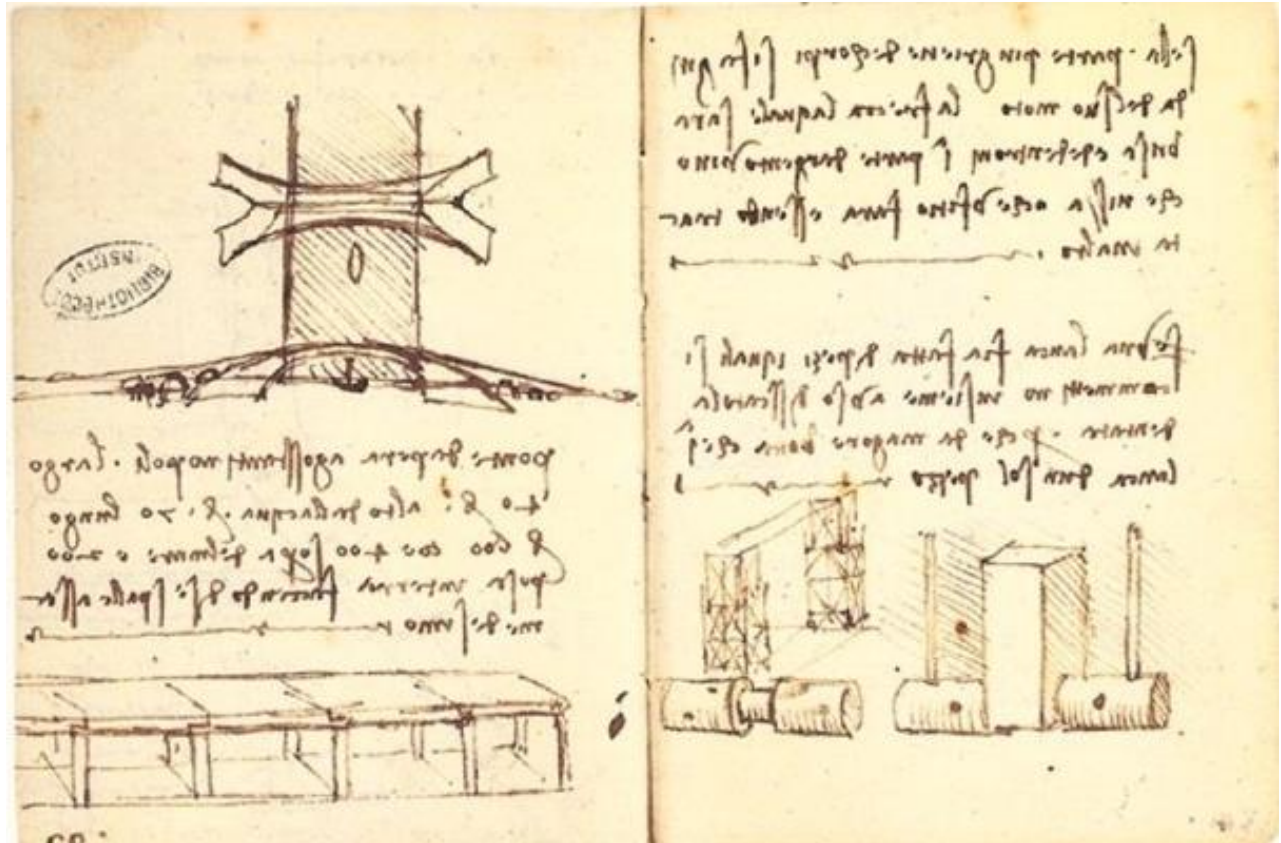

Anatomy

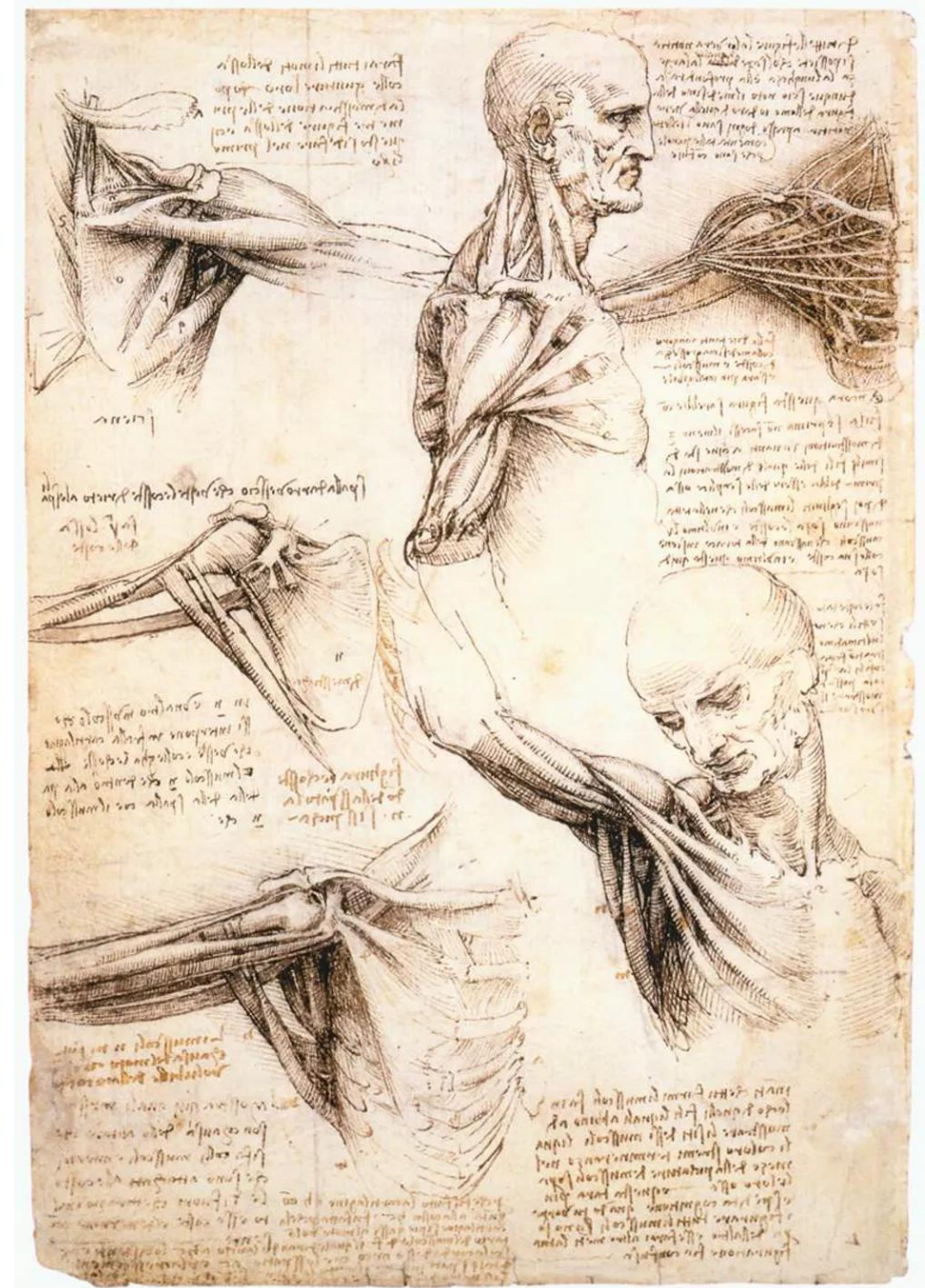
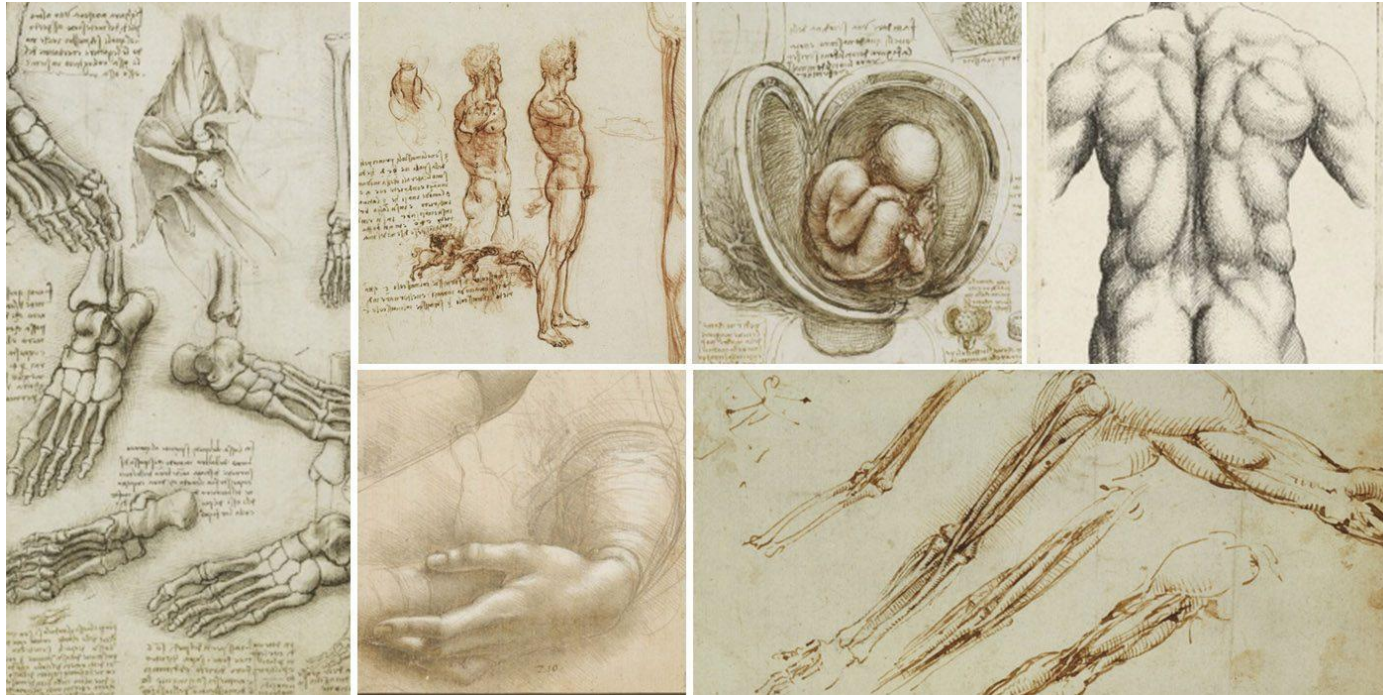

“We shall describe this mechanical structure of man by means of diagrams”

Hydraulics

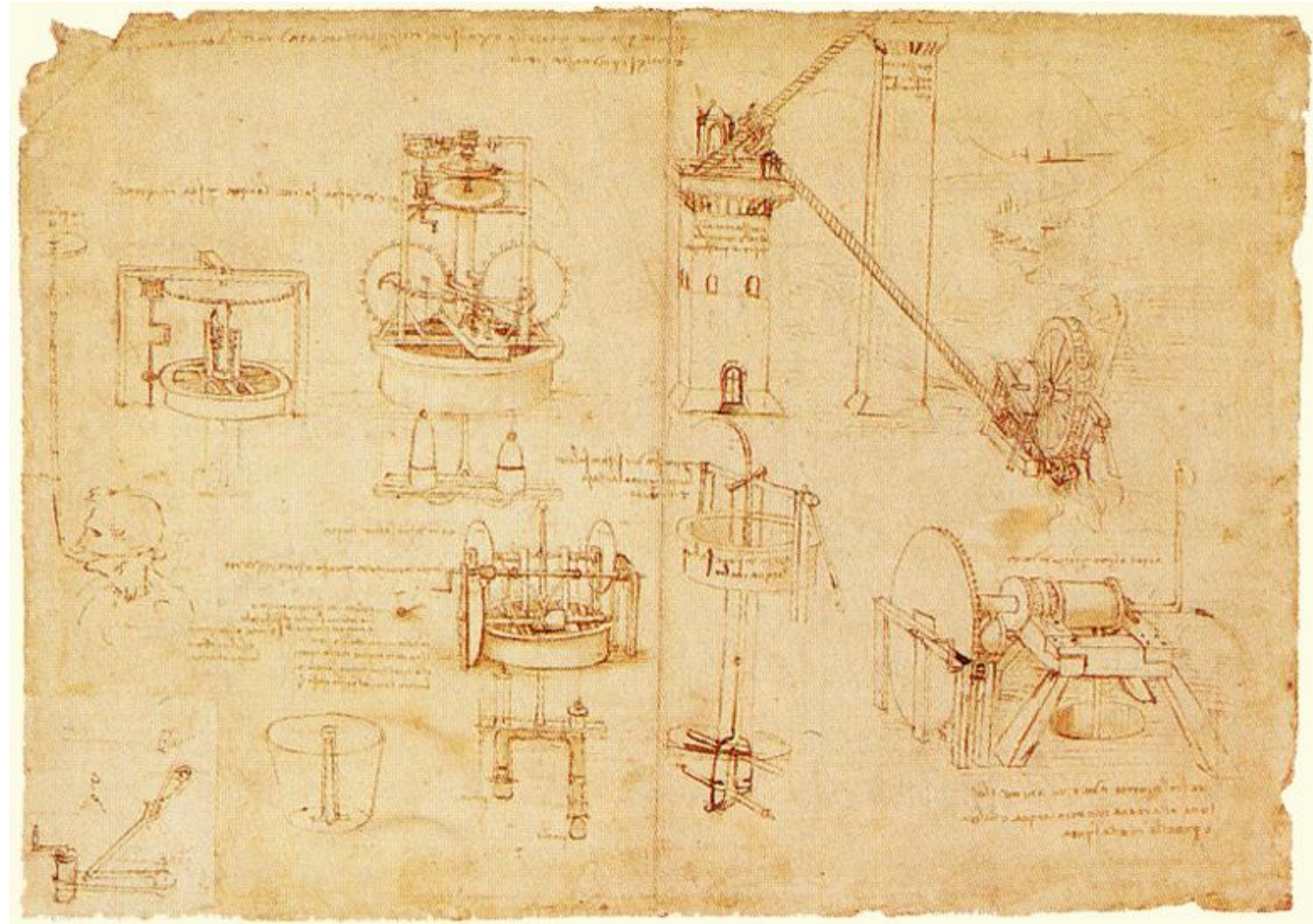

Physics and Mechanics

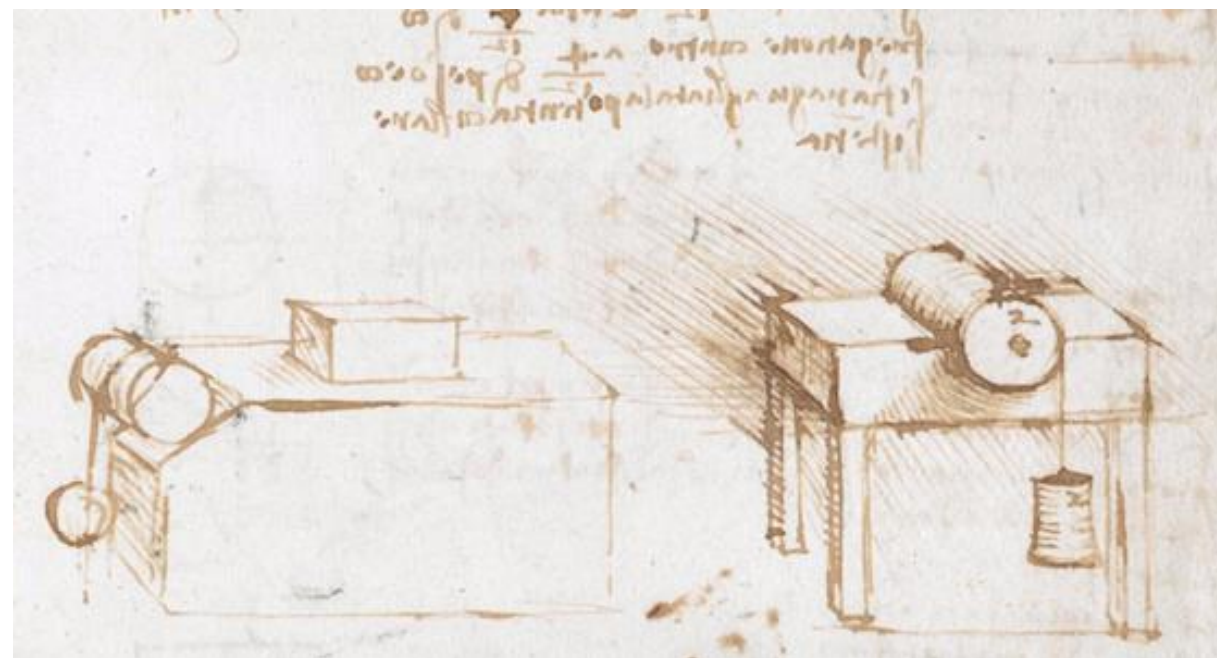
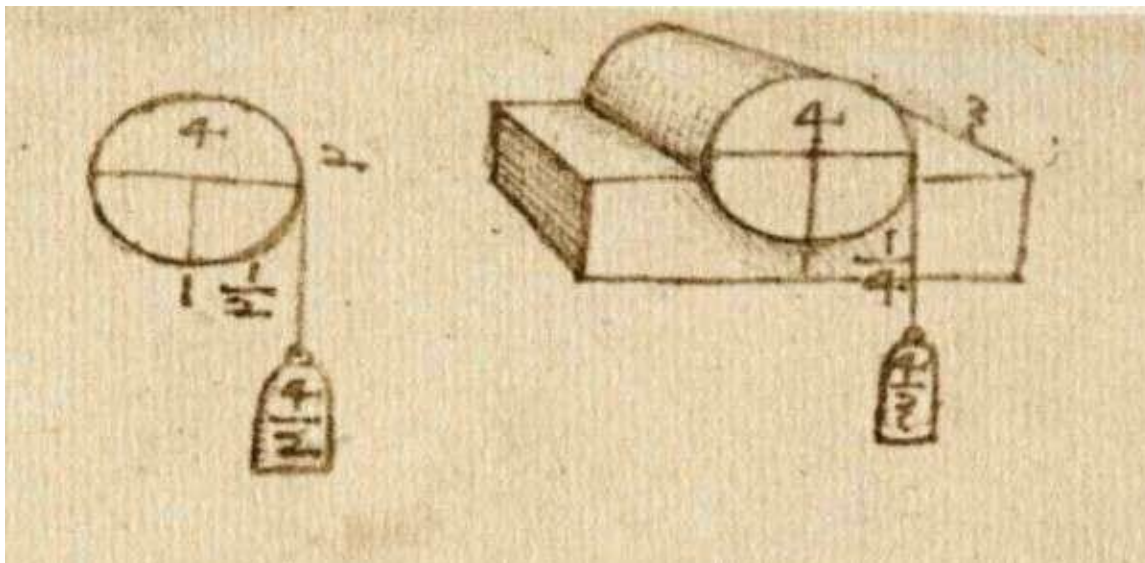
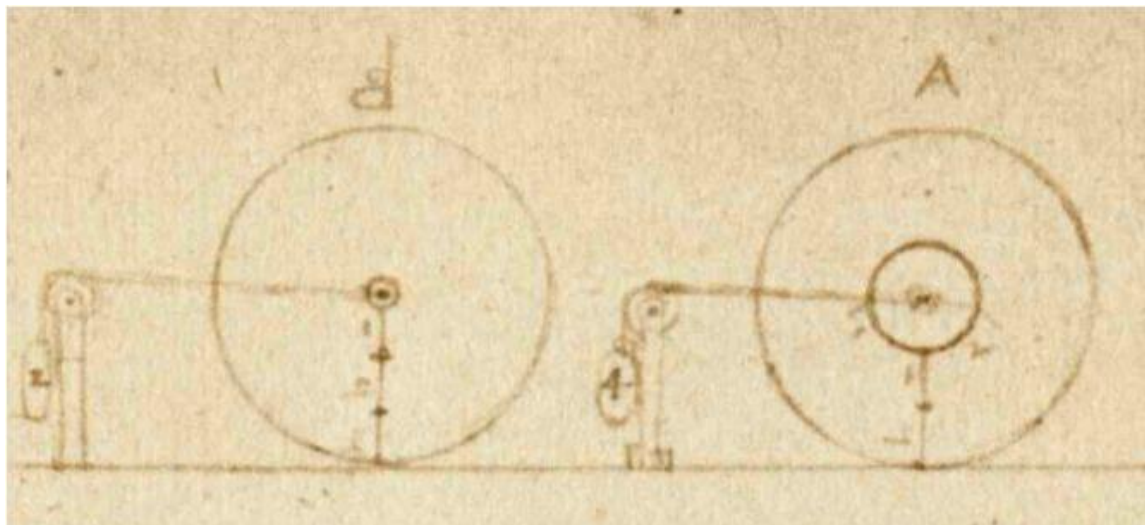

Military Engineering

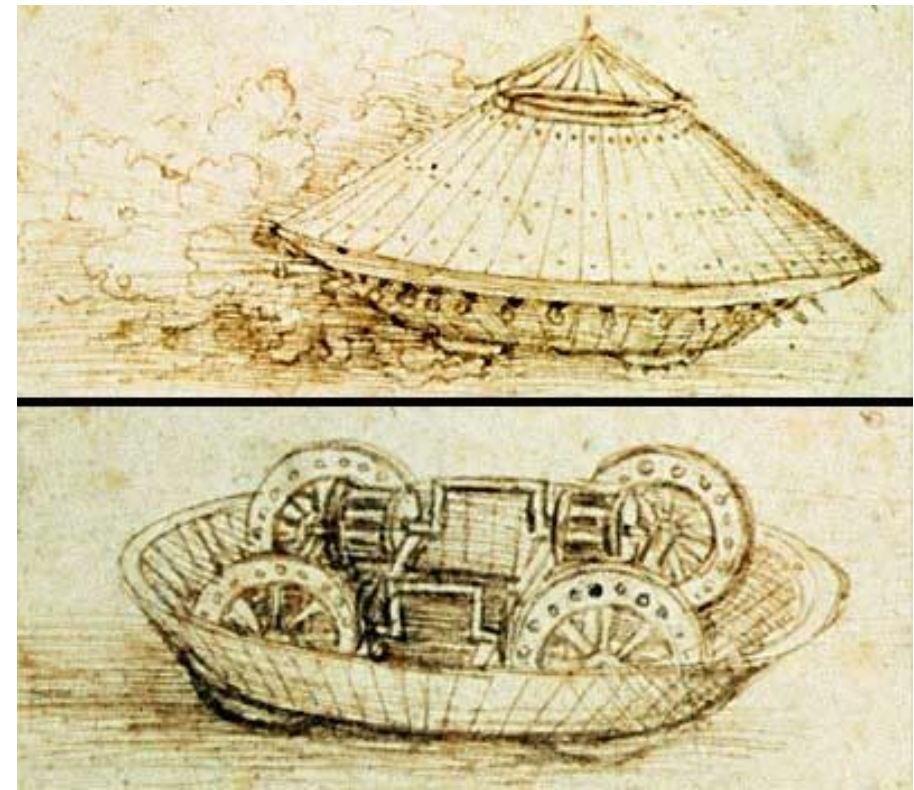
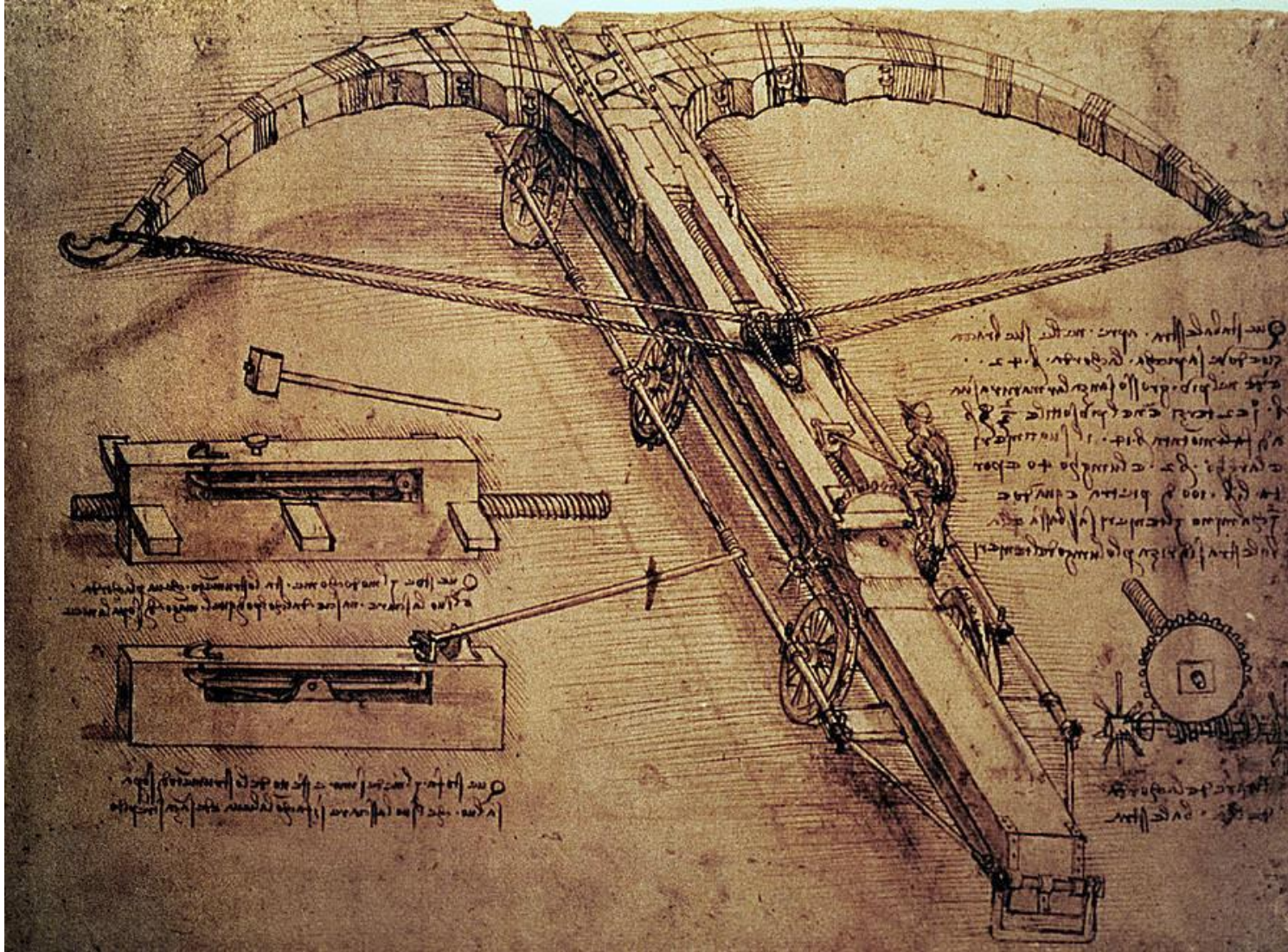

Sculpture





Music

in 11^{te} Tante.
+ *Ein Klavier Concert. Sopralied. 2 Violini, 2 Viola, 1 Flauto, 2 Oboe, 2 Fagotti,
2 Corni, 2 Clarini, Trompete & Bassen.*
1785.
in 10^{ter} Januar.
+ *Ein Quartett für 2 Violini, Viola & Violoncello.*
in 9^{ter}
+ *Ein Quartett für 2 Violini, Viola & Violoncello.*
in 10^{ter} Sonntag.
*Ein Klavier Concert. Sopralied. 2 Violini, 2 Viola, 1 Flauto, 2 Oboe,
2 Fagotti, 2 Corni, 2 Clarini, Trompete & Bassen.*
in 6^{ter} März.
+ *Ein Concert für die Instrumente für die Violoncello. A^ute für alle Instrumente. Cs
Sopralied. 2 Violini, 2 Viola, 1 Flauto, 1 Oboe, 1 Clarinetto, 1 Fagott, 2 Corni & Bassen.*

All. Vivo.
All.
Adagio. *Cresc.* *For.*
All. *Cresc.* *For.*
Adant.

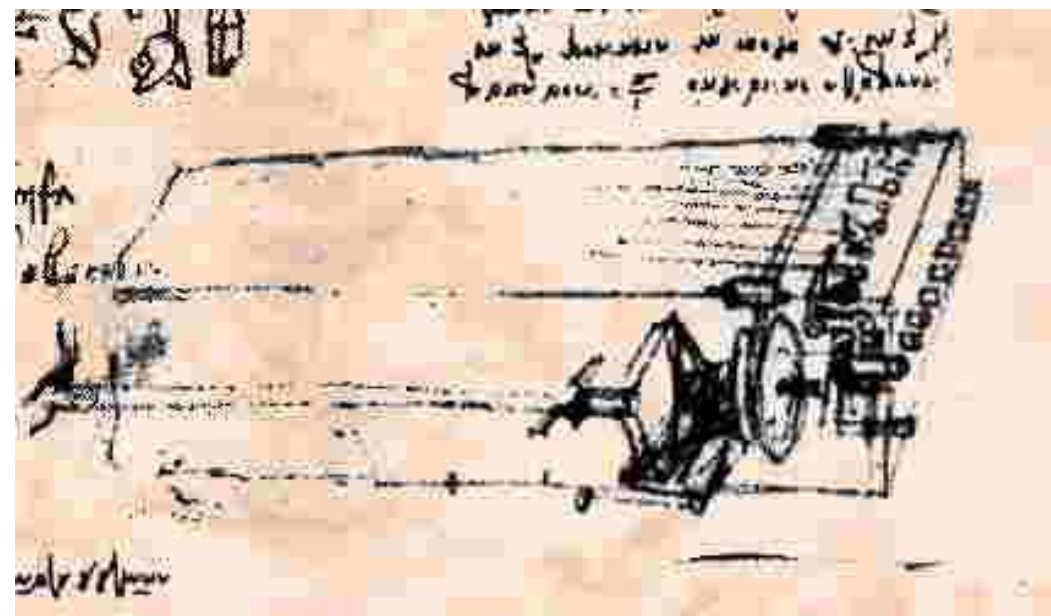
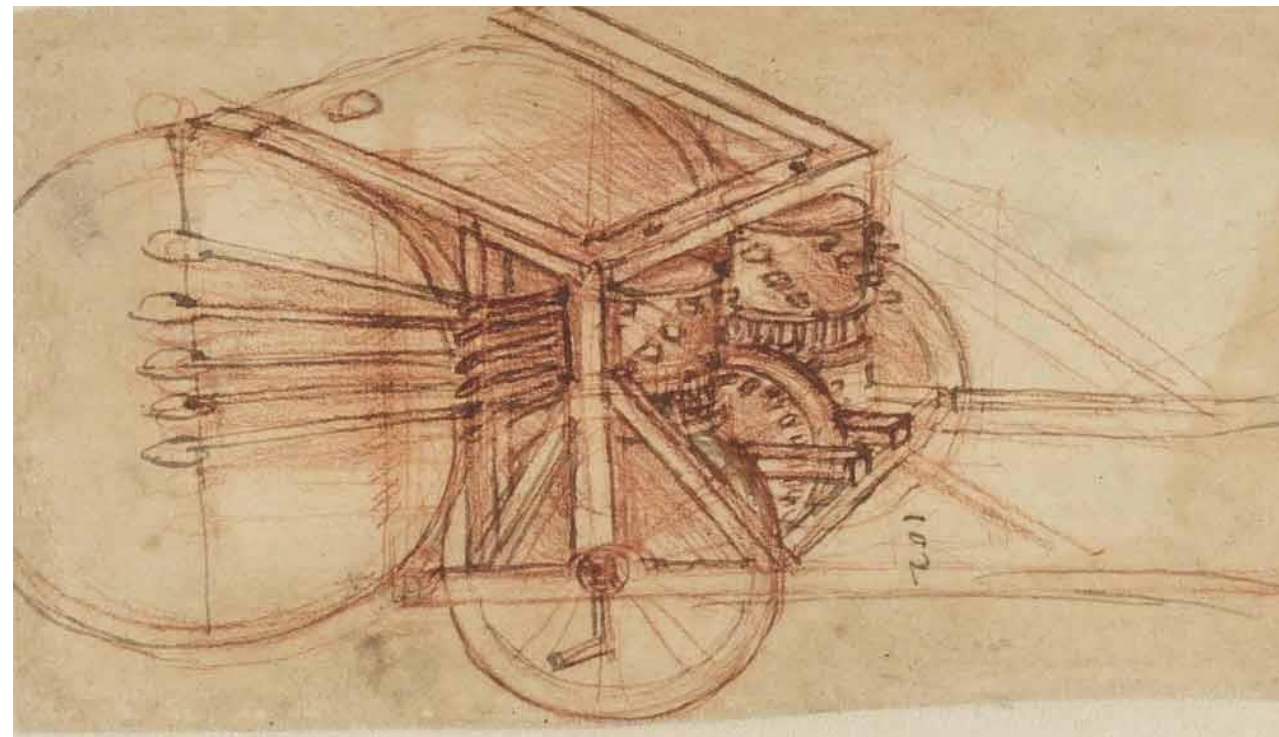
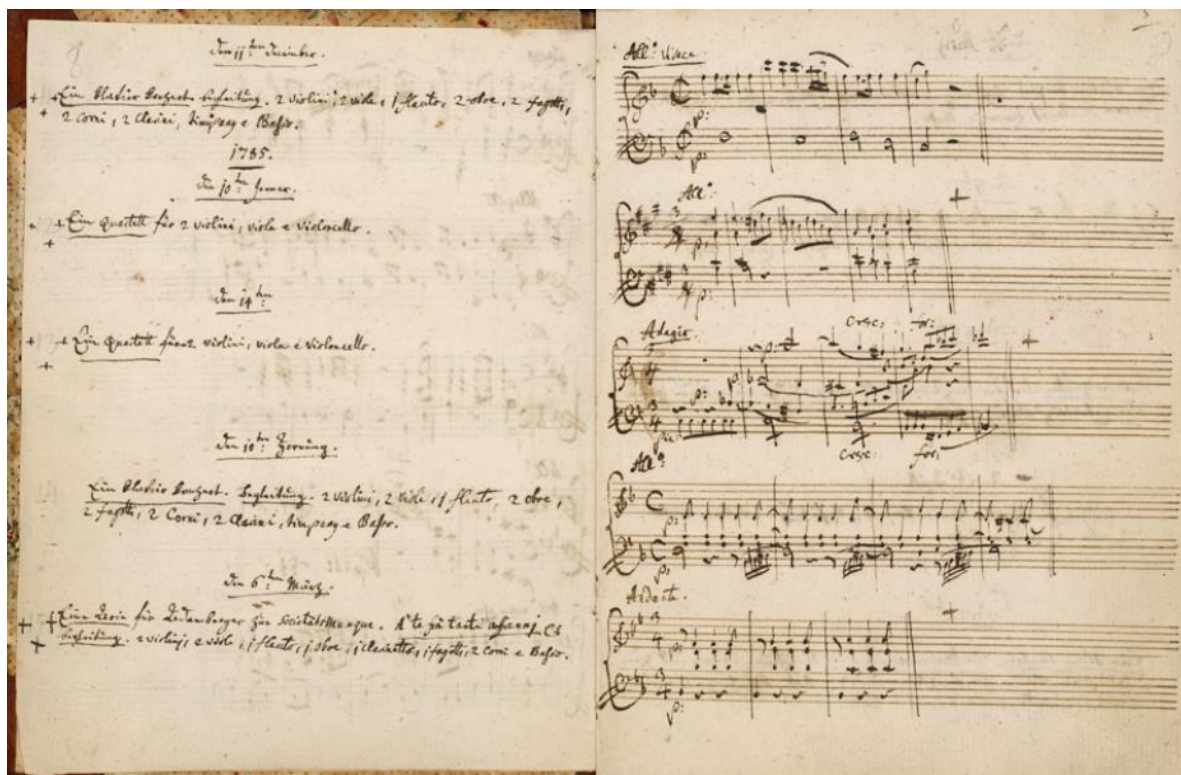

Vitruvian Man

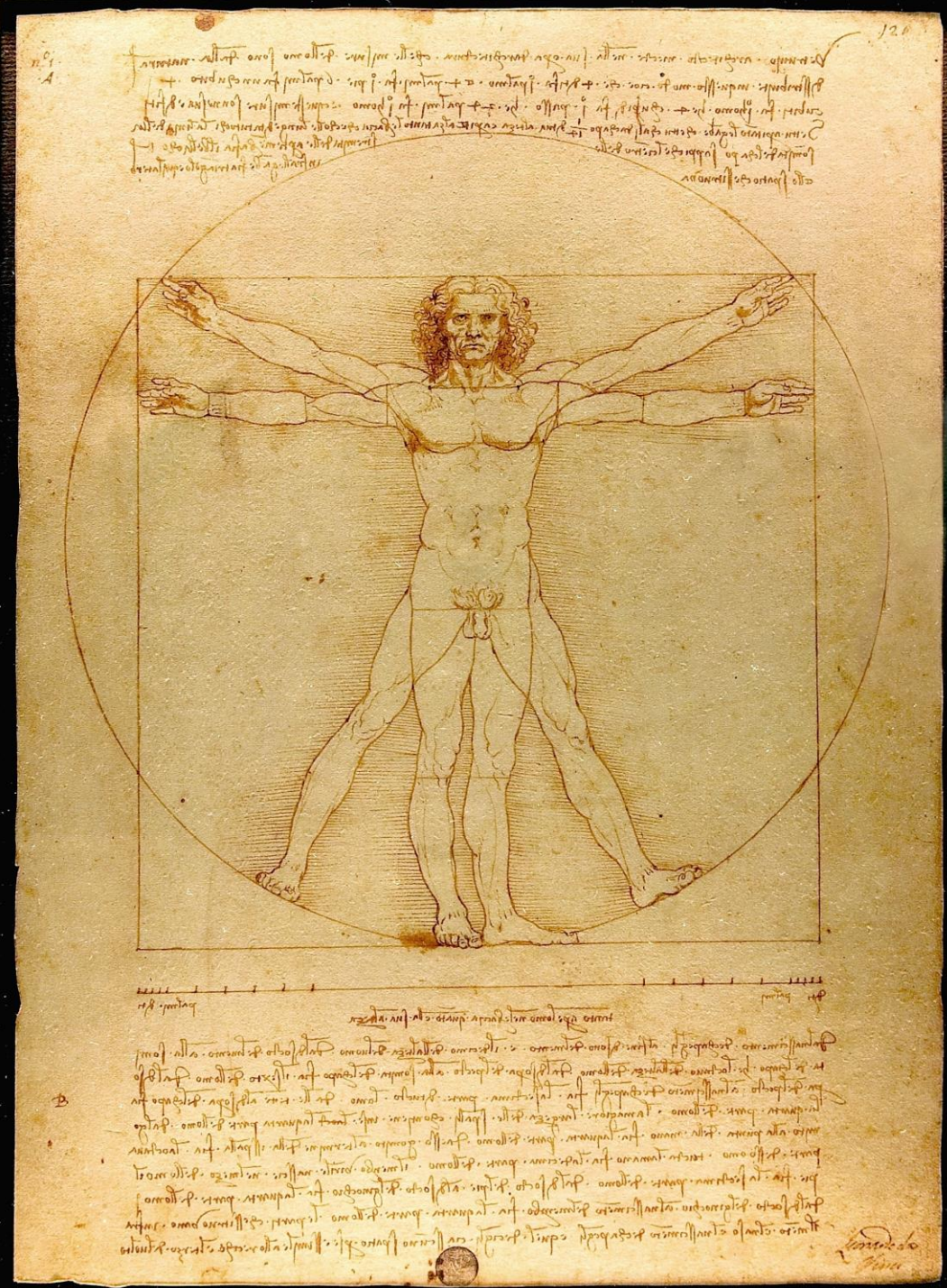
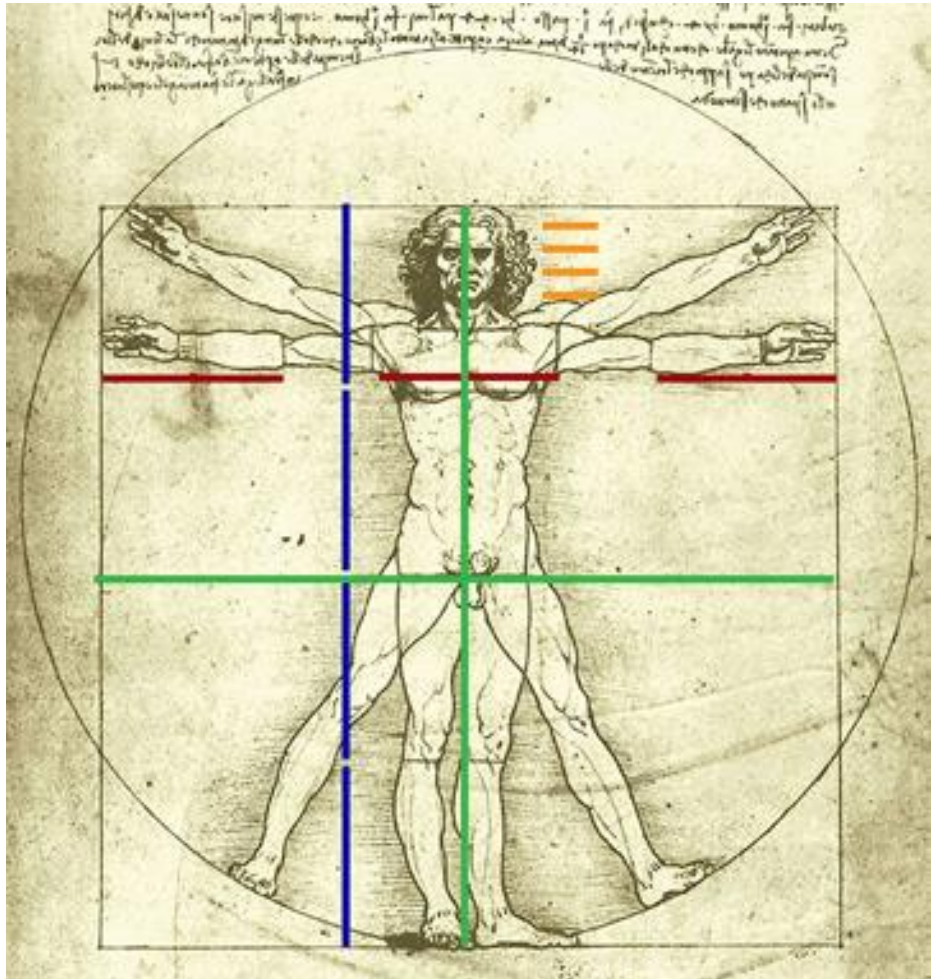

300 YEARS

LATER

Age of Enlightenment

- Defeat of Italy by Napoleon led to removal in **1796** of Leonardo's manuscripts from the Ambrosiana Library in Milan to Paris
- Began to be studied by scholars in Paris
- **Giovani Venturi** wrote work entitled, 'Essai sur la ouvrages physico-mathematiques de Leonard de Vinci'
- Brought attention to Leonardo's studies that inspired other scholars in 19th century to examine manuscripts long neglected in Milan

Franz Reuleaux (1829-1905)

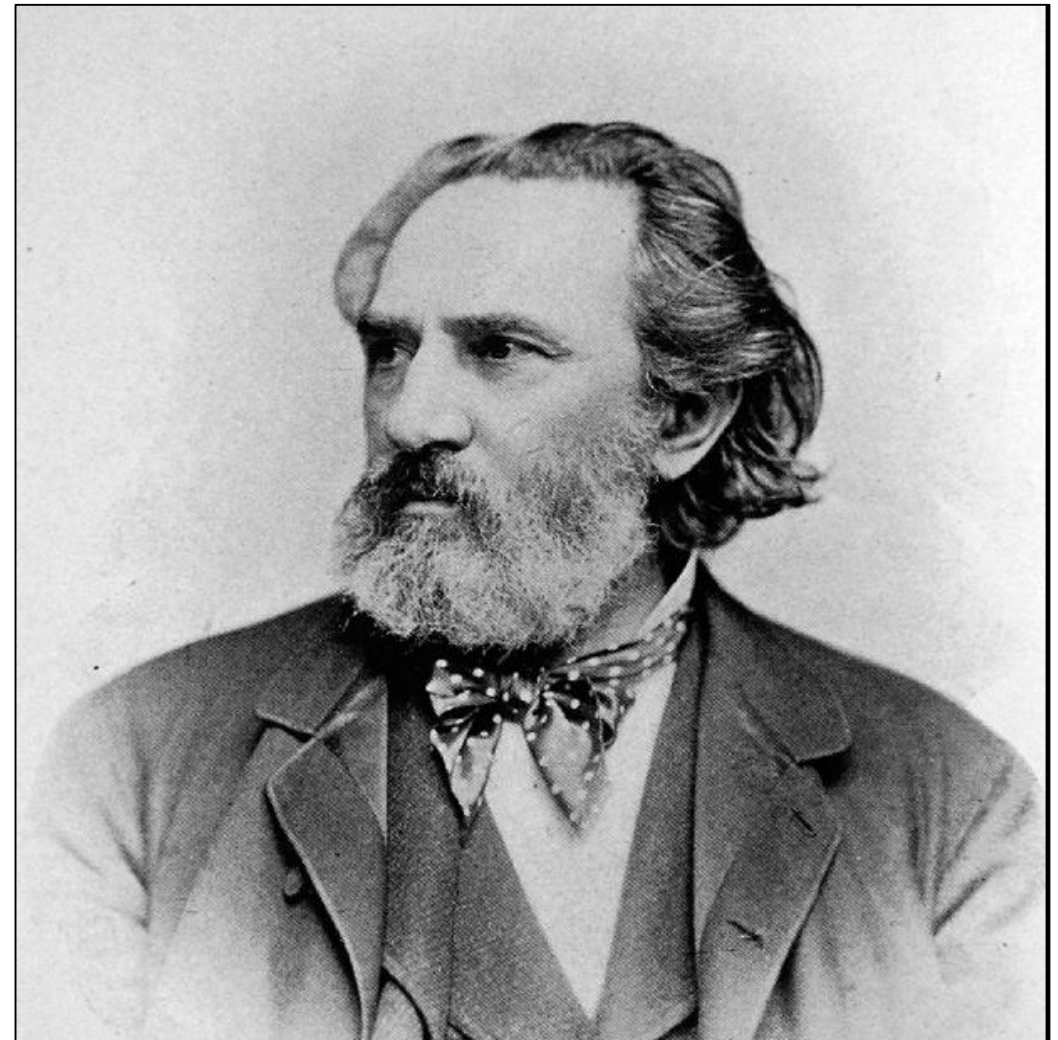
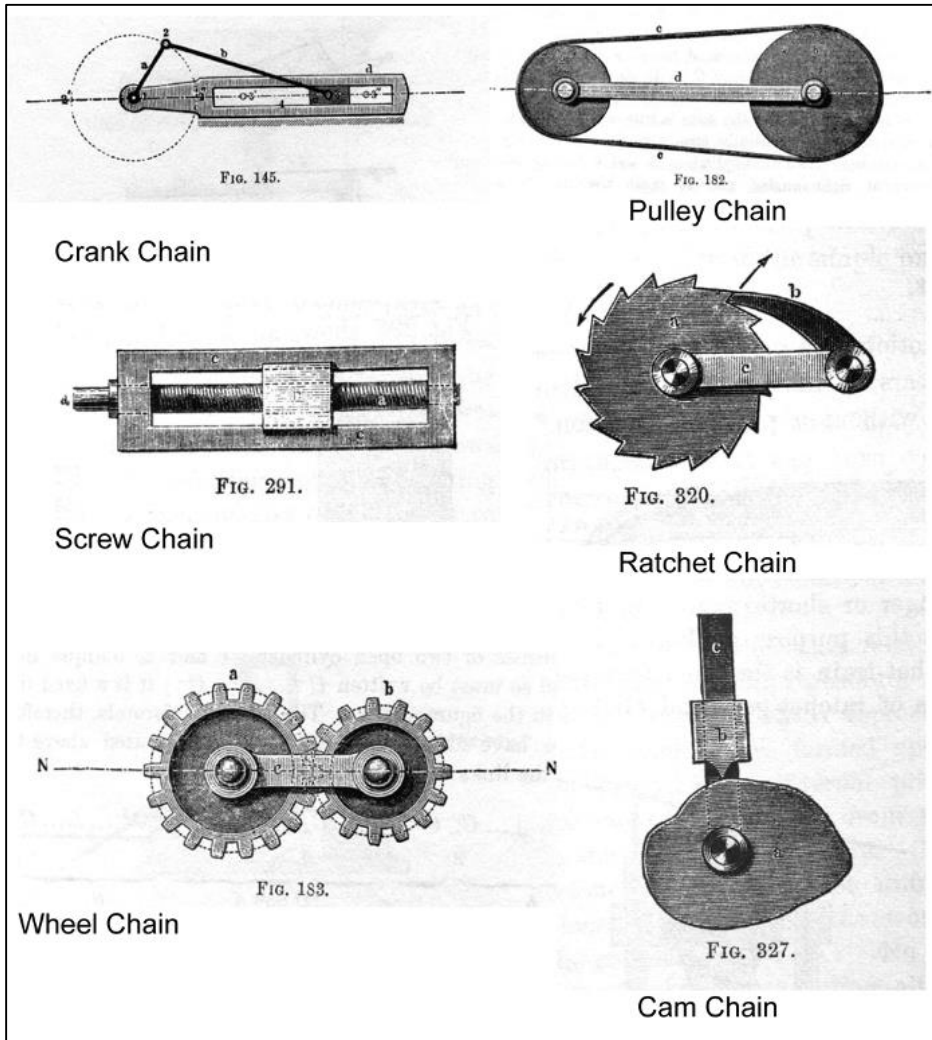

Six Classes of Kinematic Mechanisms

Kinematic Elements in Machine Design

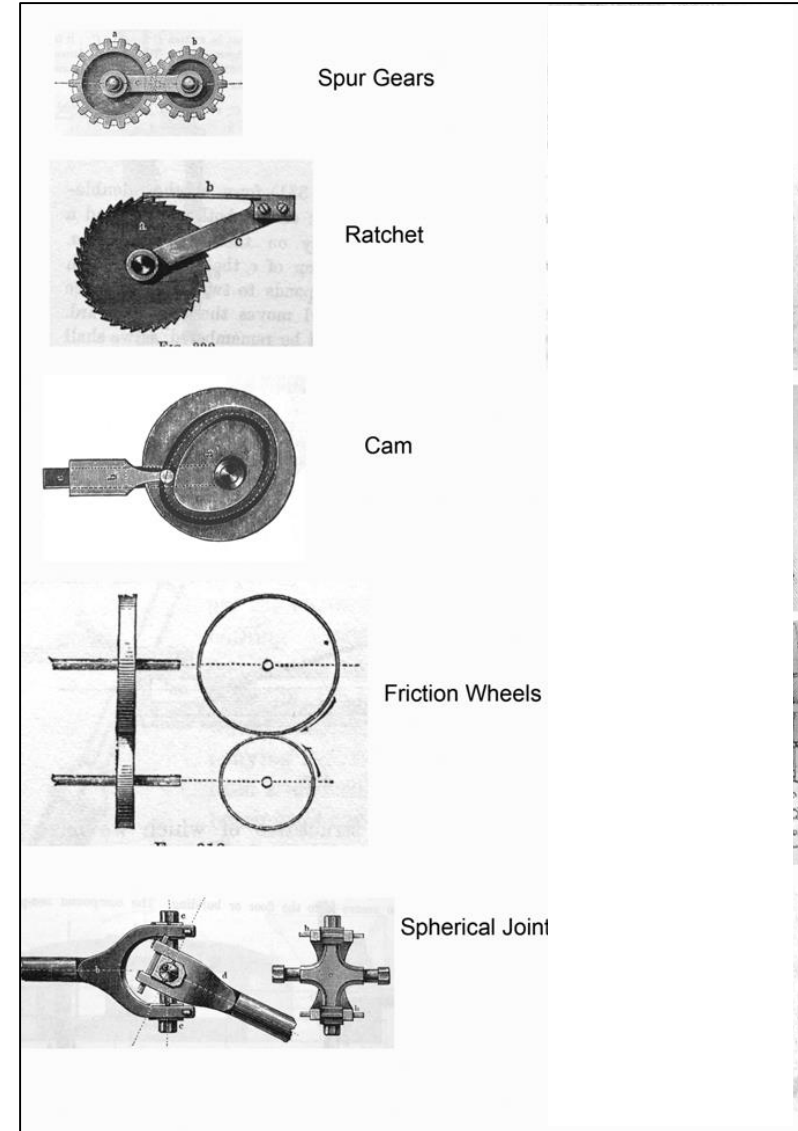
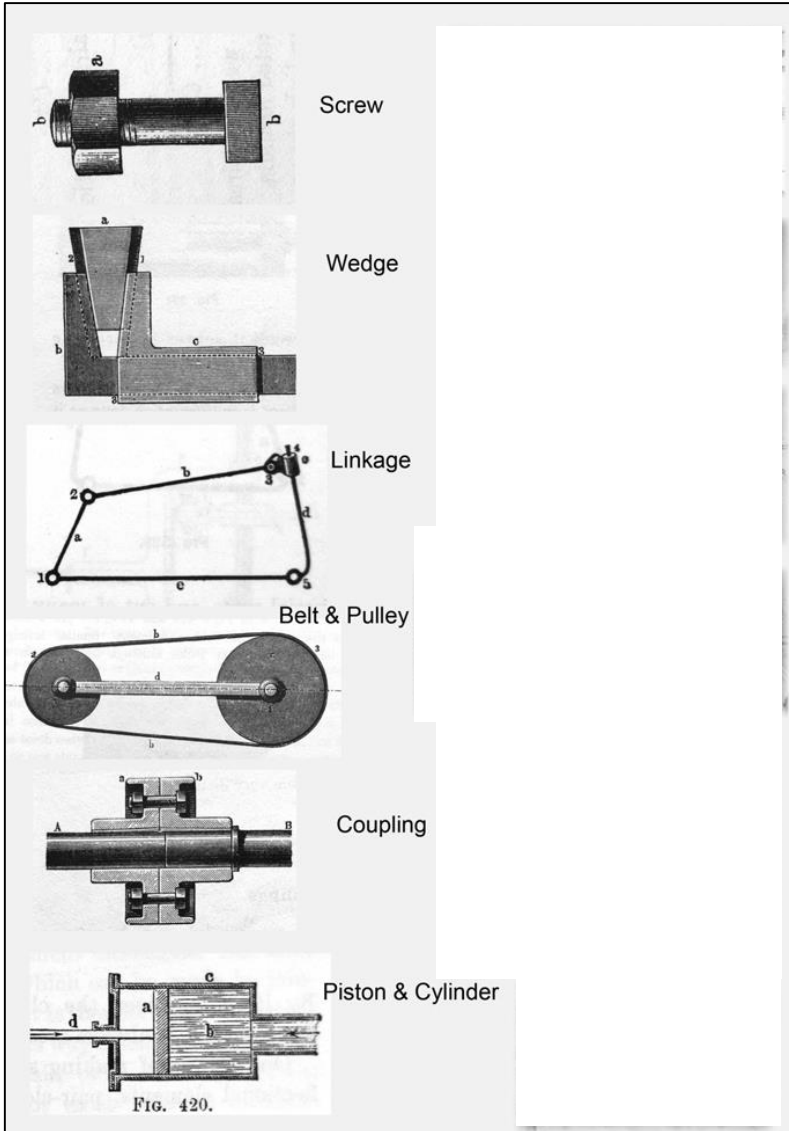

Reuleaux's 'Constructive Elements'***Kinematics of Machinery, 1876***

Screws	Section 107
Keys	Section 108
Rivets	Section 109
Bearings	Section 112
Pins, Axles and Shafts	Section 110
Couplings	Section 111
Ropes, Belts and Chains	Section 113
Friction Wheels	Section 114
Toothed Wheels	Section 115
Flywheels	Section 116
Levers, Connecting Rods	Section 117
Click Wheels	Section 119
Ratchets	Section 121
Brakes	Section 122
Engaging Gear	Section 123
Pipes	Section 125
Pump Cylinders, Pistons	Section 125
Valves	Section 126
Springs	Section 127
Cranks and Rods	Section 117
Cams	Section 145
Pulleys	Section 158

Leonardo's 'Elementi Macchinali'***Codex Madrid I***

Folio 26r
Folio 46v
—
Folio 101r
Folio 10v
Folio 62r
Folios 9r, 23r, 10r
Folio 102r
Folio 15v
Folio 35r
Folio 1r
Folio 117r
Folio 12r
Folio 10r
Folio 2r
Folio 25v
Folio 5r-b (<i>Cod. Atlanticus</i>)
Folio 115r
Folio 85r
Folio 28v
Folio 6v
Folio 155r

LDV – A Draftsman

Believed there were rational principles to art based on mathematical philosophies of perspective and proportion

Modern drafting codes still follow these practices

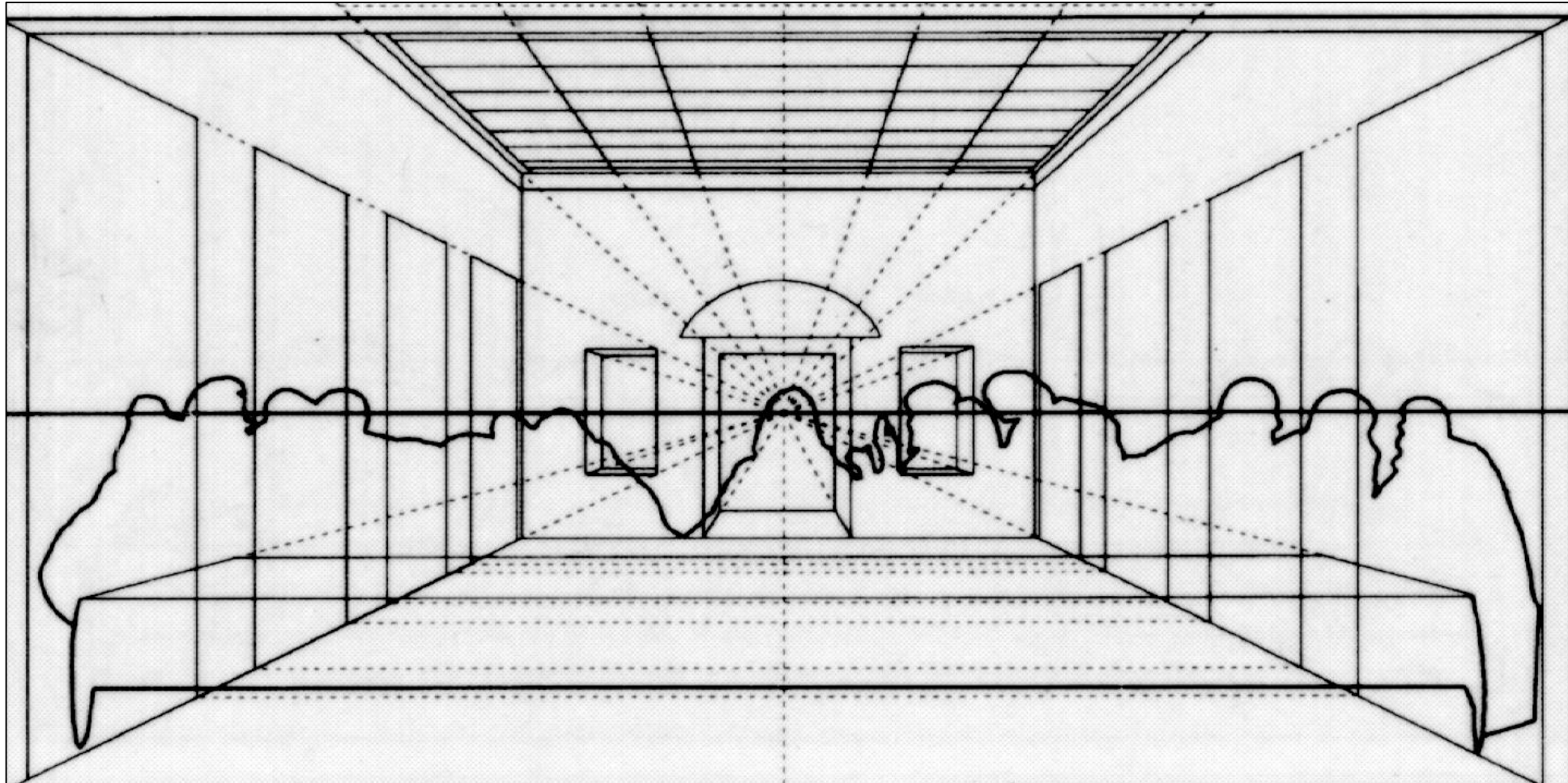

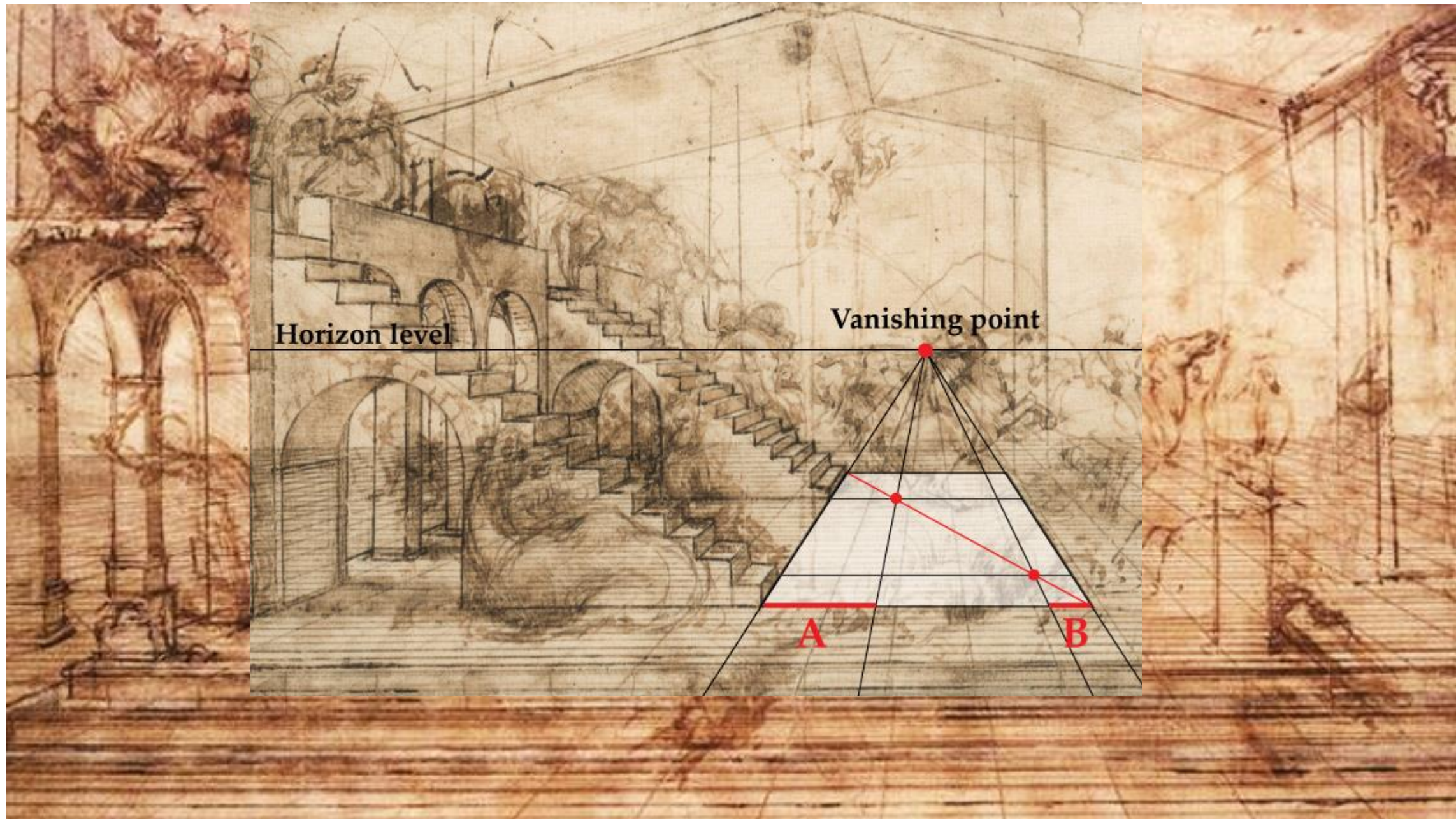

Horizon level

Vanishing point

A

B

6 5 4 3 2 1

REV.	DESCRIPTION	DATE
A	INITIAL RELEASE	8/30/2019

A

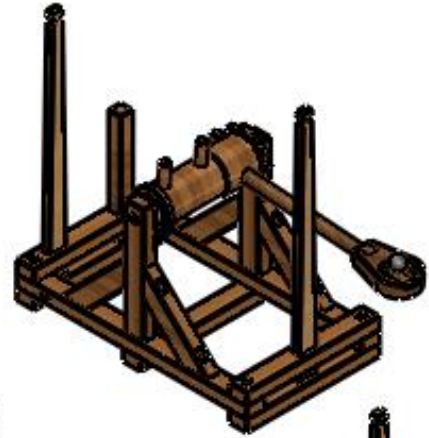
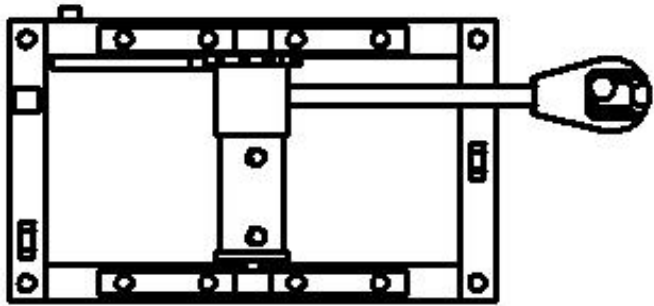

A

B

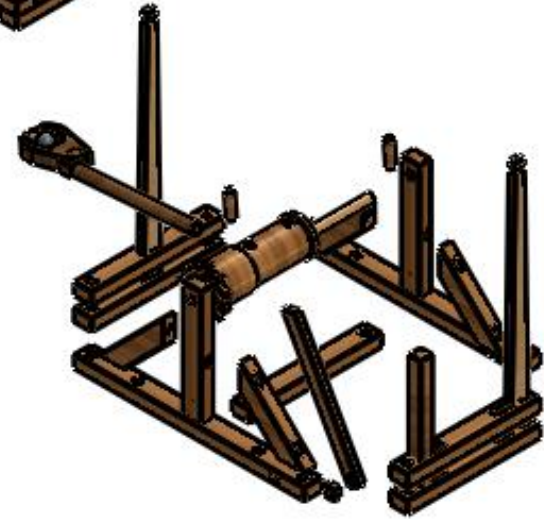
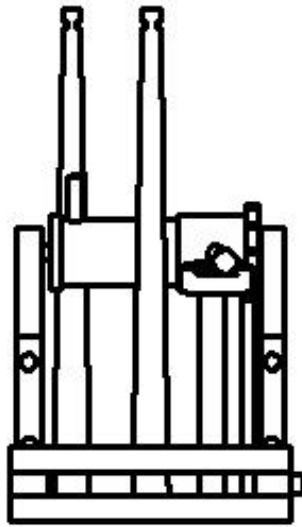
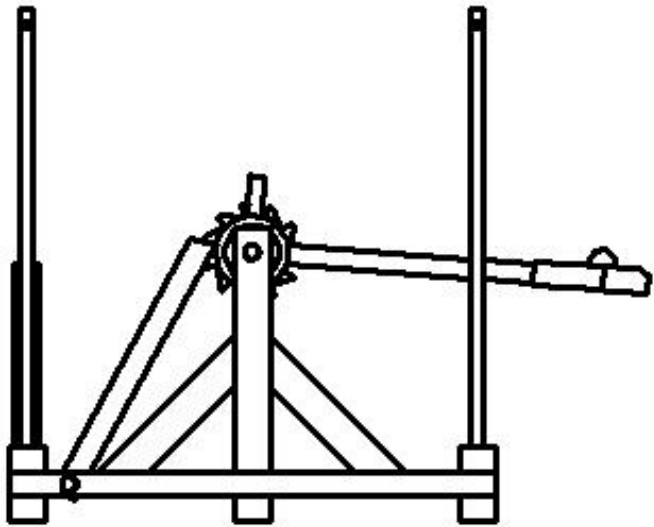

B

C

D

PROJECT NAME	Leonardo 1452 1	
PROJECT NUMBER	1	
DATE	8/30/2019	DESCRIPTION
DESIGNED BY	DJR	001
APPROVED BY		REV. A
<small>PROPERTY AND INFORMATION CONTAINED HEREIN IS THE PROPERTY OF THE DESIGN CENTER FOR INNOVATION & EDUCATION. ALL RIGHTS RESERVED. NO PART OF THIS PUBLICATION MAY BE REPRODUCED OR TRANSMITTED IN ANY FORM OR BY ANY MEANS, ELECTRONIC OR MECHANICAL, INCLUDING PHOTOCOPYING, RECORDING, OR BY ANY INFORMATION STORAGE AND RETRIEVAL SYSTEM.</small>		

6 5 4 3 2 1

da Vinci in Your Toothbrush

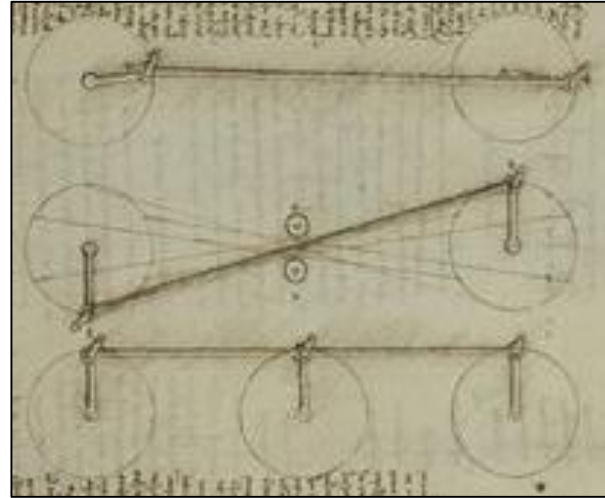
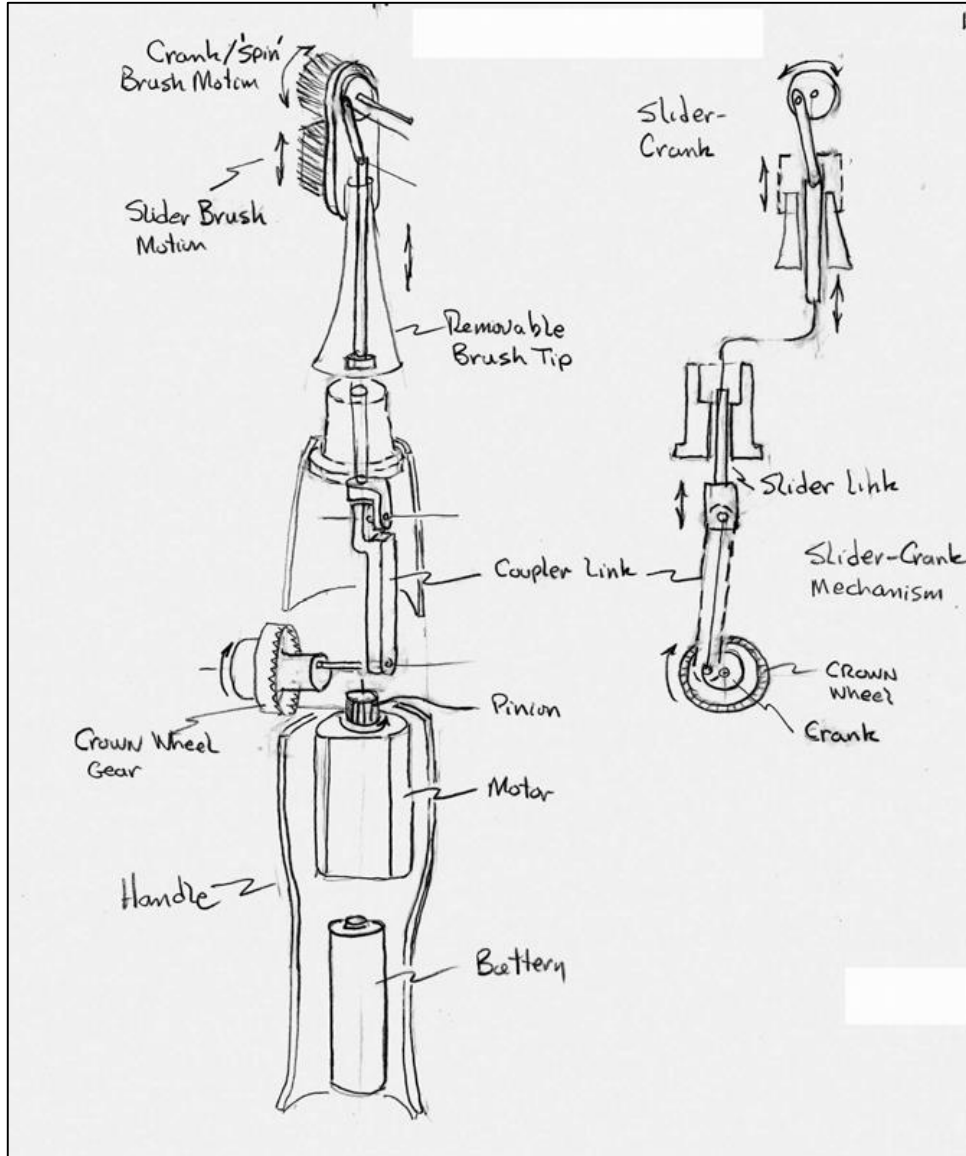

Four-link mechanism

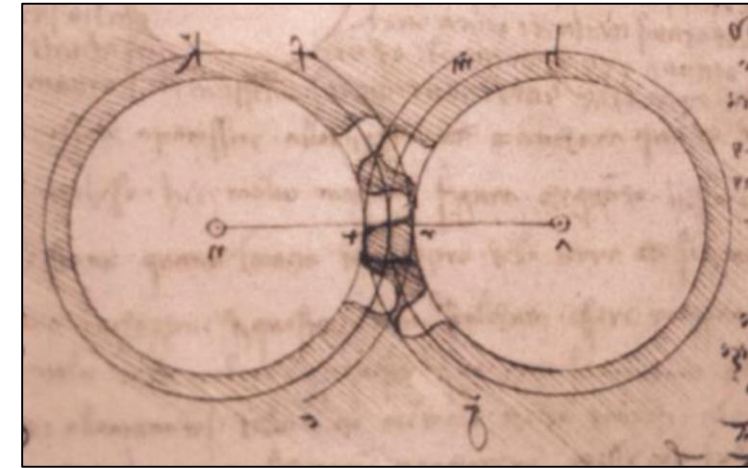

Gear and pinion

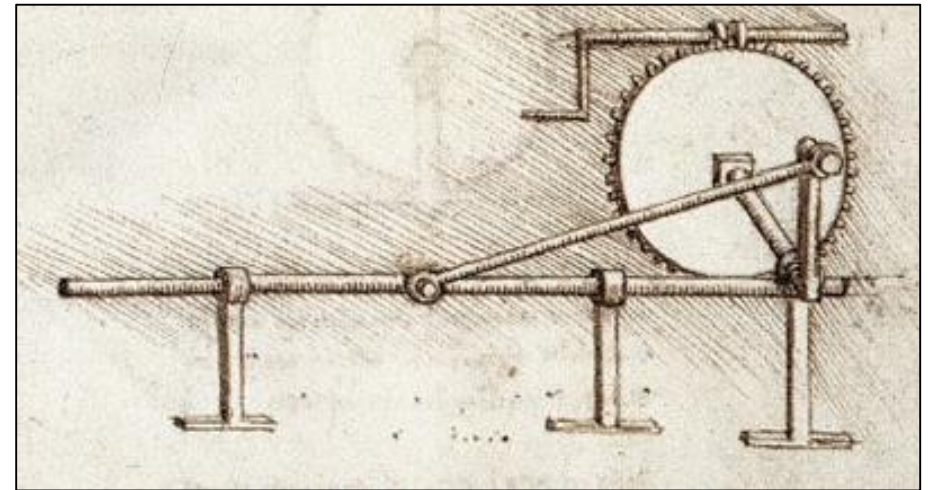

Slider-crank mechanism

da Vinci in Your Toothbrush

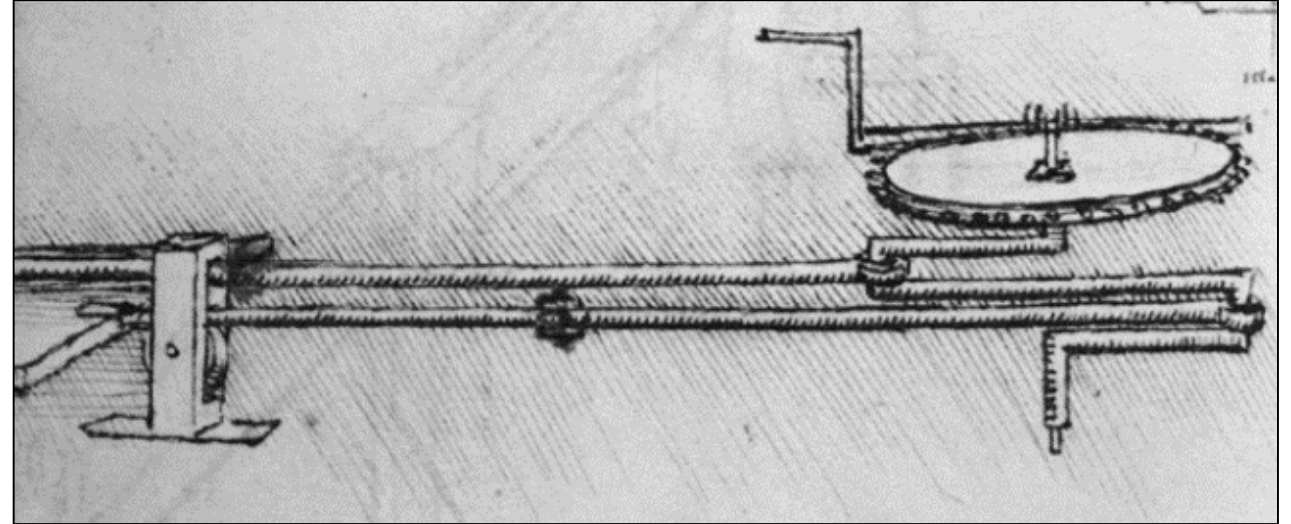
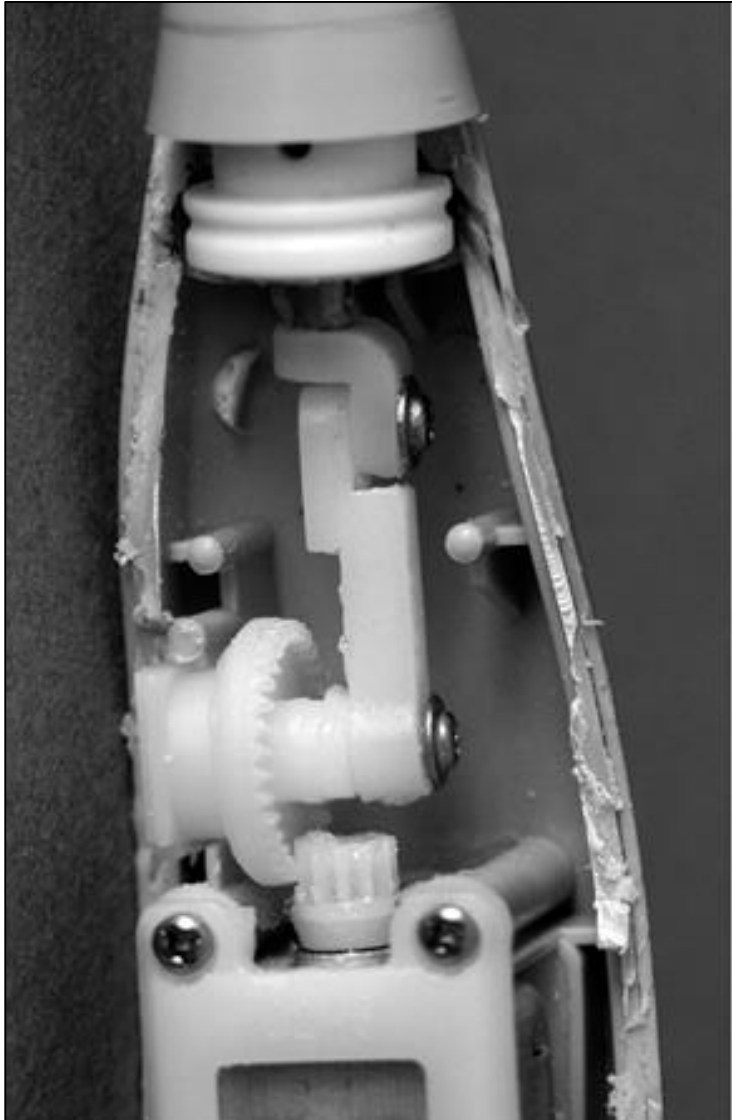

Double slider-crank mechanism and worm gear drive

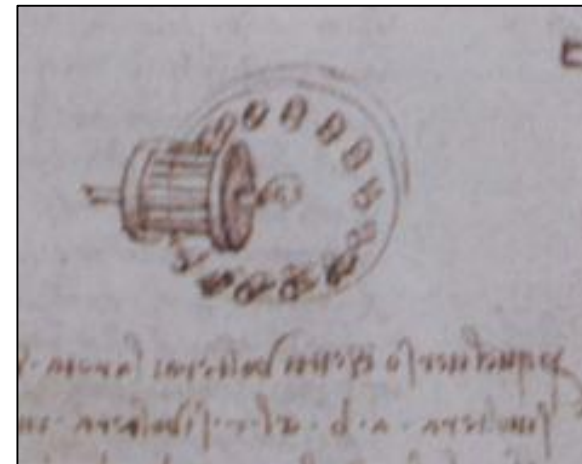

Crown wheel gear and lantern pinion

Before Leonardo

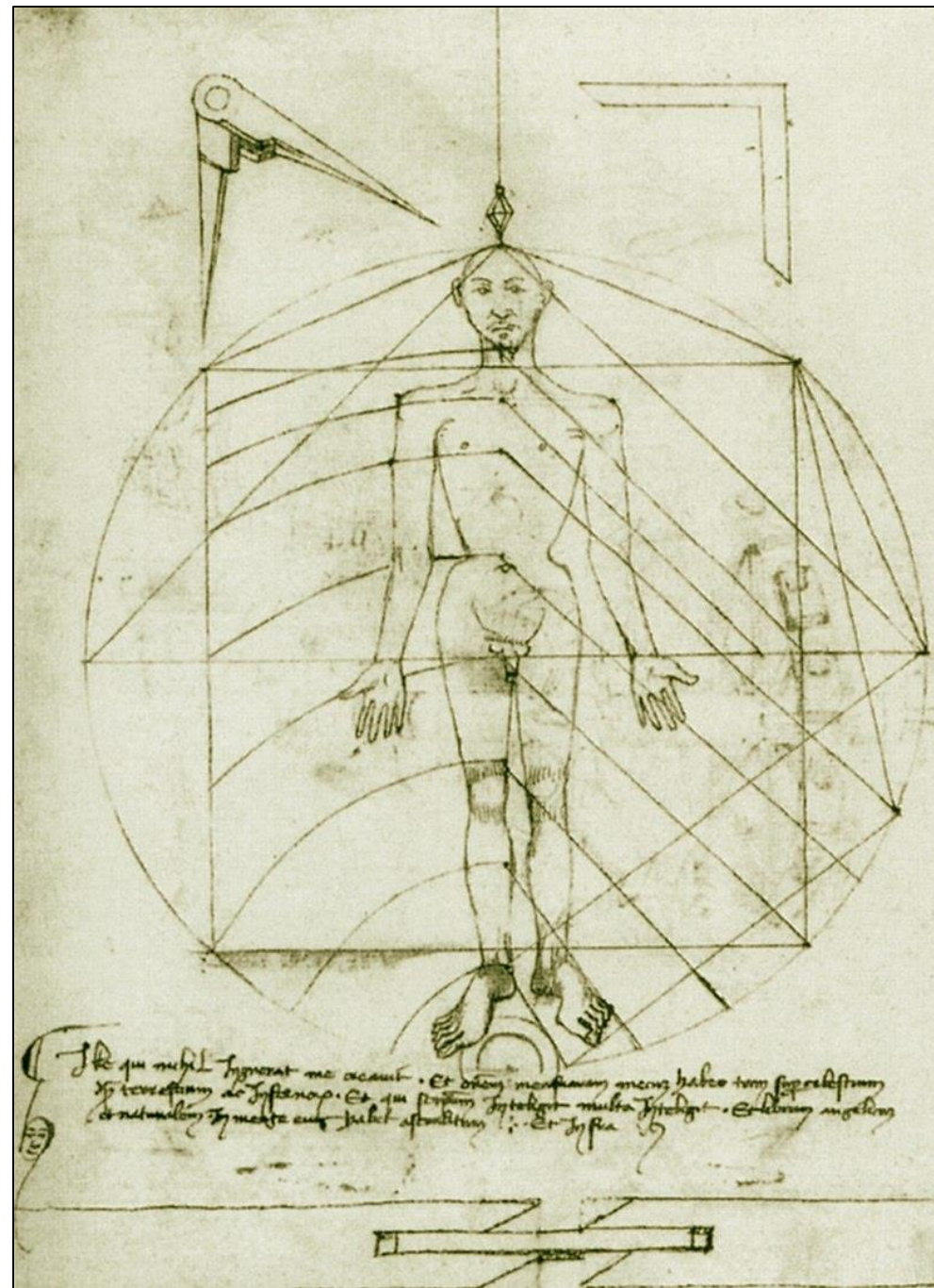
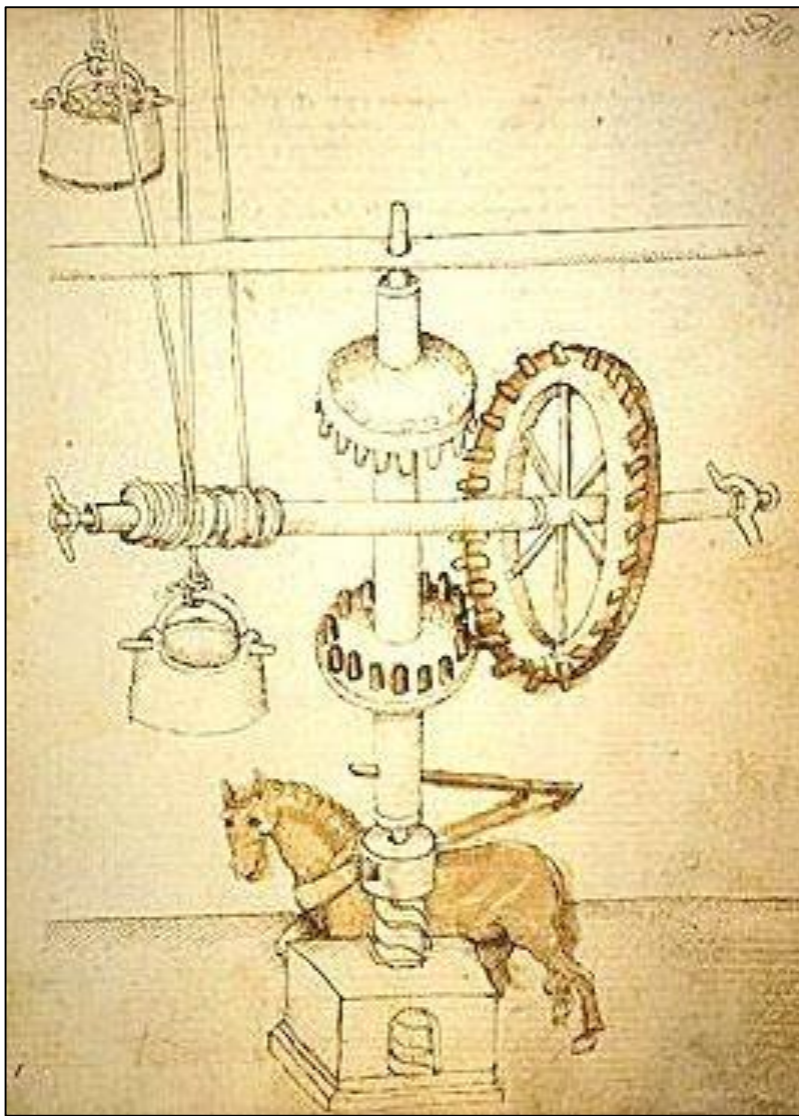

C Ille qui nihil ignorat me occidit. Et orem mentium meorum habeo tum super celestium
et terrestrium ac infernarum. Et qui primum intelligit multa intelligit. Et omnium angelorum
et naturalium et mente eum habet assemblans. Et supra

A Lasting Impact

"Leonardo da Vinci was like a man who awoke too early
in the darkness, while the others were all still asleep"
-Sigmund Freud

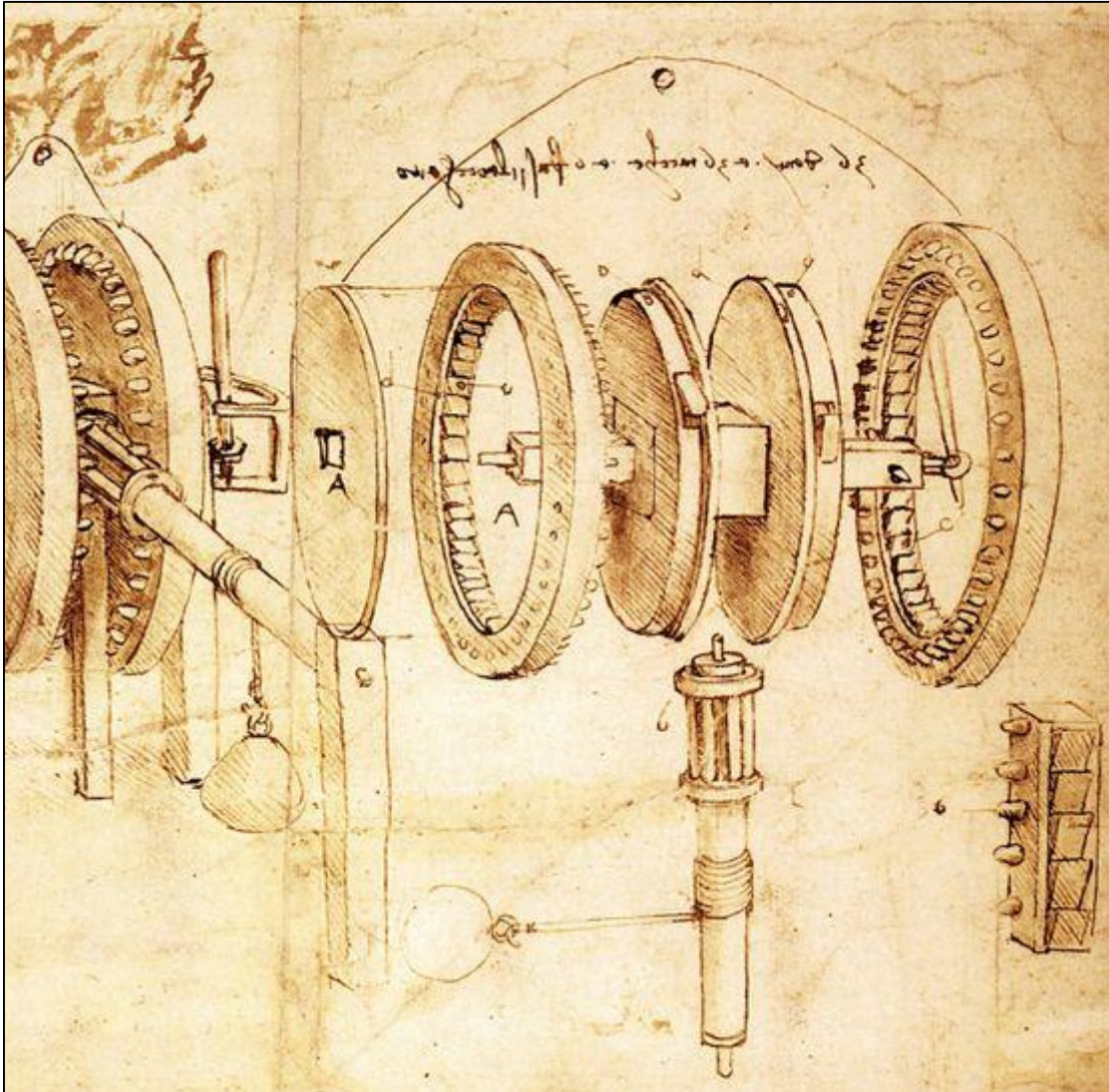

Any Questions?



Mechanical Engineering
UNIVERSITY OF COLORADO **BOULDER**